

**AGENDA**  
**WYOMING CITY COUNCIL MEETING**  
**CITY COUNCIL CHAMBERS**  
**MONDAY, FEBRUARY 5, 2018, 7:00 P.M.**

- 1) Call to Order**
- 2) Invocation** – Pastor Bruce Osbeck, Faith Reformed Church  
*If you wish and are able, please stand for the invocation. The Pledge of Allegiance will immediately follow the invocation.*
- 3) Pledge of Allegiance**
- 4) Roll Call**
- 5) Student Recognition**
- 6) Approval of Minutes**  
From the Regular Meeting of January 15, 2018
- 7) Approval of Agenda**
- 8) Public Hearings**  
*If you wish to speak to an item during a public hearing you are welcome to do so. It is important to note this is not an opportunity for dialog or debate; this is an opportunity to provide comment to the City Council. Comments made during a public hearing may become part of the meeting's permanent record. Upon approaching the podium, please begin by providing your name and address. There is a 3 minute limit per person.*  
**7:01 p.m.** To Consider Approval of an Application for an Industrial Facilities Exemption Certificate in the City of Wyoming for Agropur Inc.
- 9) Public Comment on Agenda Items**  
*This public comment period is reserved for comment on agenda items only. If you wish to speak about an item that is not on the agenda, please hold your comments until the acknowledgement of visitors at the end of the meeting. It is important to note this is not an opportunity for dialog or debate; this is an opportunity to provide comment to the City Council. Upon approaching the podium, please begin by providing your name and address. There is a 3 minute limit per person.*
- 10) Presentations and Proclamations**
  - a) Presentations
  - b) Proclamations
- 11) Petitions and Communications**
  - a) Petitions
  - b) Communications
- 12) Reports from City Officers**
  - a) From City Council
  - b) From City Manager
- 13) Budget Amendments**

**14) Consent Agenda**

*All items under this section are considered to be routine and will be enacted by one motion with no discussion. If discussion is desired by a Councilmember, that member may request removal from the Consent Agenda.*

- a) To Appoint Marietta Sutton as a Member of the Community Enrichment Commission for the City of Wyoming
- b) To Reappoint Kent Vanderwood to the Kent County Waste-to-Energy Advisory Committee
- c) To Set a Public Hearing to Establish an Industrial Development District for Gable Holdings II, LLC in the City of Wyoming (February 19, 2018 at 7:01 p.m.)

**15) Resolutions**

- d) To Approve the Application of Agropur, Inc. Located at 5252 Clay Ave SW, for an Industrial Facilities Exemption Certificate in the City of Wyoming
- e) To Authorize the City Manager to Enter into Purchase Agreements and Reduce the Sales Price for Site 36 Projects Meeting Certain Criteria
- f) To Approve an Amendment to Section 9.1(f) of the Charter of the City of Wyoming to Renew the Public Safety Millage for the City of Wyoming
- g) To Authorize the Write-off of Delinquent 2011 City Property Taxes
- h) To Authorize the Mayor and City Clerk to Accept a Donation of Funds from the Wyoming Senior Fellowship Club, Inc. and to Authorize the Related Budget Amendment

**16) Award of Bids, Contracts, Purchases, and Renewal of Bids and Contracts**

- i) To Authorize the Mayor and City Clerk to Execute a Helipad License Agreement with Metro Health – University of Michigan Health
- j) To Authorize Payment to Grand Elk Railroad, Inc., for Annual Maintenance of Traffic Control Devices at Railroad Crossings in the City of Wyoming
- k) To Concur with Repair of a Vactor Truck, Rental of a Vactor Truck and to Authorize Payment to Jack Doheny Companies, Inc.
- l) To Extend the Bid from Core and Main, Metron-Farnier and Ferguson Waterworks and Accept a Quotation from ETNA Supply for Water Meters, Strainers and Meter Equipment
- m) To Accept a Proposal from ThyssenKrupp Elevator to Perform Corrective Maintenance on an Elevator
- n) To Concur with Additional Repairs of Two Pumps at the Water Treatment Plant
- o) For Award of Bids
  - 1. Generators
  - 2. Trailer

**17) Ordinances**

- 1-18 To Amend Section 90-32 of the Code of the City of Wyoming by Adding Subsection (109) Thereto to Rezone 2440, 2446, 2450 and 2520 Vangie Drive; 2453 Batt Drive; and 61, 71, 81, 101 and 111 Plaster Creek Boulevard from R-2 Single Family Residential to I-1 Light Industrial (First Reading)

**18) Informational Material**

**19) Acknowledgment of Visitors**

*This public comment period is an opportunity to share concerns or present topics to the*

*City Council that were not part of this meeting's agenda. This is not an opportunity for dialog with Council, but Council may make referrals or request staff to follow up. Please provide your name and address when approaching the podium. There is a 3 minute limit per person.*

**20) Closed Session** (as necessary)

**21) Adjournment**

RESOLUTION NO. \_\_\_\_\_

RESOLUTION TO APPOINT MARIETTA SUTTON AS A MEMBER OF  
THE COMMUNITY ENRICHMENT COMMISSION FOR THE CITY OF WYOMING

WHEREAS:

1. Marietta Sutton has submitted an application requesting appointment to the Community Enrichment Commission for the City of Wyoming.
2. A vacancy exists in an unexpired term ending June 30, 2018 on the Community Enrichment Commission.
3. It is the desire of the City Council that Marietta Sutton be appointed to fill that unexpired term on the Community Enrichment Commission.

NOW, THEREFORE, BE IT RESOLVED:

1. The City Council for the City of Wyoming, Michigan does hereby appoint Marietta Sutton as a member of the Community Enrichment Commission of the City of Wyoming for the unexpired term ending June 30, 2018.

Moved by Councilmember:

Seconded by Councilmember:

Motion Carried        Yes  
                                  No

I hereby certify that the foregoing Resolution was adopted by the City Council for the City of Wyoming, Michigan at a regular session held on February 5, 2018.

\_\_\_\_\_  
Kelli A. VandenBerg, Wyoming City Clerk

RESOLUTION NO. \_\_\_\_\_

RESOLUTION TO REAPPOINT KENT VANDERWOOD TO THE KENT COUNTY  
WASTE-TO-ENERGY ADVISORY COMMITTEE

WHEREAS:

1. The City of Wyoming is entitled to representation on the Kent County Waste-to-Energy Advisory Committee.
2. It is the desire of the Wyoming City Council to reappoint Councilmember Kent Vanderwood as a Wyoming representative to the Kent County Waste-to-Energy Advisory Committee.

NOW, THEREFORE, BE IT RESOLVED:

1. The City Council for the City of Wyoming, Michigan, does hereby reappoint Councilmember Kent Vanderwood as a member of the Kent County Waste-to-Energy Advisory Committee.

Moved by Councilmember:  
Seconded by Councilmember:  
Motion Carried        Yes  
                                  No

I hereby certify that the foregoing Resolution was adopted by the City Council for the City of Wyoming, Michigan at a regular session held on February 5, 2018.

\_\_\_\_\_  
Kelli A. VandenBerg, Wyoming City Clerk

RESOLUTION NO. \_\_\_\_\_

RESOLUTION TO SET A PUBLIC HEARING  
TO ESTABLISH AN INDUSTRIAL DEVELOPMENT DISTRICT FOR  
GABLE HOLDINGS II, LLC IN THE CITY OF WYOMING

WHEREAS:

1. The City of Wyoming has the authority to establish Industrial Development Districts within the City of Wyoming under the provisions of Act 198 of Public Acts of 1974, as amended.
2. Gable Holdings II, LLC has requested that the City establish an Industrial Development District for the properties located at 6156 Burlingame Ave SW, 6010 Burlingame Ave SW, and 1240 60<sup>th</sup> Street SW, Wyoming, MI.
3. Prior to establishing such districts, it is necessary to first hold a public hearing at which the owners of the affected property and any other resident or taxpayer of the City can be given an opportunity to comment on the establishment of an Industrial Development District.

NOW, THEREFORE, BE IT RESOLVED:

1. The City Council shall hold a public hearing on February 19, 2018 at 7:01 p.m., at Wyoming City Hall, 1155 28<sup>th</sup> Street SW, Wyoming, MI 49509, at which the owners of property located within the proposed Industrial Development District and other residents or taxpayers of the City shall be given an opportunity to comment on the establishment of the proposed district to be comprised of the property described on the attached Exhibit A, which is incorporated by reference, and commonly known as 6156 Burlingame Ave SW, 6010 Burlingame Ave SW, and 1240 60<sup>th</sup> Street SW, Wyoming, MI.
2. Notice of this hearing shall be given to the applicant, the Assessor, and a representative of each affected taxing unit, and shall be posted in City Hall.

Moved by Councilmember:

Seconded by Councilmember:

Motion Carried        Yes  
                                  No

I hereby certify that the foregoing Resolution was adopted by the City Council for the City of Wyoming, Michigan at a regular session held on February 5, 2018.

\_\_\_\_\_  
Kelli A. VandenBerg, Wyoming City Clerk

ATTACHMENT:

Staff Report

Exhibit A – Legal Descriptions

Resolution No. \_\_\_\_\_

## STAFF REPORT

Date: January 30, 2018  
Subject: Gable Holdings II, LLC Industrial Development District  
From: Megan Sall, Assistant City Manager  
Meeting Date: February 5, 2018

---

### Recommendation:

Staff recommends the creation of an Industrial Development District at 6156 Burlingame Avenue, 6010 Burlingame Avenue and 1240 60<sup>th</sup> Street.

### Sustainability Criteria:

Environmental Quality – Approval of this district will promote economic development activity on this property. Furthermore, the proposed development plans are consistent with Wyoming’s land use plan.

Social Equity – Approval of this district will contribute to development in the area of 60<sup>th</sup> Street and Burlingame Avenue, thereby increasing accessibility to employment for Wyoming residents.

Economic Strength – Approval of this district will encourage investment and grow the City’s tax base. It will also provide additional employment opportunities to the area.

### Discussion:

Gable Holdings II, LLC, the developer involved in this project, is requesting the approval of an Industrial Development District at the aforementioned property at the southeast corner of Burlingame Avenue and 60<sup>th</sup> Street. An Industrial Development District (IDD) is a municipal-approved designation that allows qualified property owners and tenants to apply for PA 198 Industrial Facility Tax Abatements (IFT), which provide a 50% abatement on real property investments. Per the abatement policy, projects cannot begin prior to establishment of an IDD.

In the past, IDD’s have been established on a case by case basis in accordance with each IFT application. However, in an effort to move at the speed of business and maximize efficiency, staff is supportive of Gable Holding’s request so that qualified industrial or high-tech companies can start their projects right away as needed, without having to wait for an IDD to be established. IFT applications will be expected at a later date, in accordance with the abatement policy.

It should be noted that Gable Ventures does not own all of the affected properties as a result of land sales and parcel splits. However, as the developer for the area they do represent the majority of the owners in their desire to speed development. In addition, there are no ill consequences for properties that possess an IDD designation.

Exhibit A

6156 Burlingame Ave SW:

Parcel Number: 41-21-02-600-004

412102600004 NFRL 1/2 NWFRL 1/4 EX N 412.5 FT ALSO PART OF SW 1/4 NWFRL 1/4 COM 1166.30 FT S 1D 05M 15S W ALONG W SEC LINE FROM NW COR OF SEC TH N 89D 22M 00S E 1323 FT M/L TO W 1/8 LINE TH N 0D 10M 00S W 14.0 FT M/L ALONG W 1/8 LINE TO N 1/8 LINE TH N 89D 23M 00S W ALONG N 1/8 LINE 1322.95 FT TO W SEC LINE TH S 1D 05M 15S W 33.62 FT TO BEG EX THAT PART LYING SLY & WLY OF A LINE COM 1166.30 FT S 1D 05M 15S W ALONG W SEC LINE & S 89D 20M 00S E FROM NW COR OF SEC 1133.55 FT TO NLY LINE OF M-6 & BEG OF SD LINE - TH N 68D 15M 10S WLY ALONG SD NLY R/W 523.58 FT TH N 72D 43M 48S W ALONG SD NLY R/W 567.67 FT TO A PT BEING 98.43 FT PERP FROM W SEC LINE TH N 1D 05M 15S E 440.81 FT TH N 6D 23M 51S W TO N SEC LINE & PT OF ENDING SD LINE \* SEC 2 T5N R12W 37.81 A. SPLIT/COMBINED ON 06/29/2016 FROM 41-21-02-100-056; Split on 10/25/2017 into 41-21-02-600-008, 41-21-02-600-009, 41-21-02-600-010;

6010 Burlingame Ave SW:

Parcel Number: 41-21-02-600-001

N 280.5 FT OF NFRL 1/2 NWFRL 1/4 LYING E OF A LINE COM 407.79 FT S 1D 05M 15S W ALONG W SEC LINE & 98.43 FT S 88D 54M 45S E FROM NW COR OF SEC TH N 6D 23M 51S W ALONG SD LINE TO S R/W OF 60TH ST /66 FT WIDE/ EX E 500 FT \* SEC 2 T5N R12W 13.41 A. SPLIT/COMBINED ON 06/29/2016 FROM 41-21-02-100-054; Split on 10/25/2017 into 41-21-02-600-005, 41-21-02-600-006, 41-21-02-600-007;

1240 60<sup>th</sup> St SW:

Parcel Number: 41-21-02-600-002

N 280.5 FT OF E 300 FT OF NWFRL 1/4 \* SEC 2 T5N R12W 1.93 A.

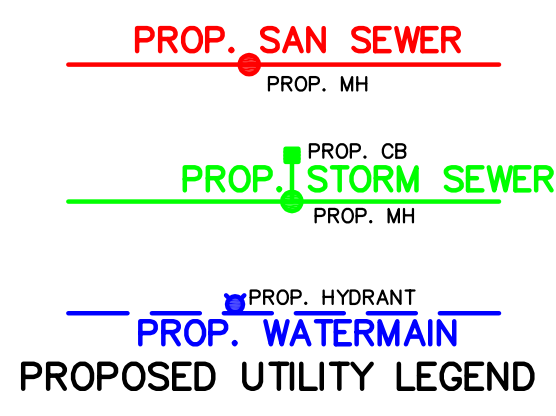
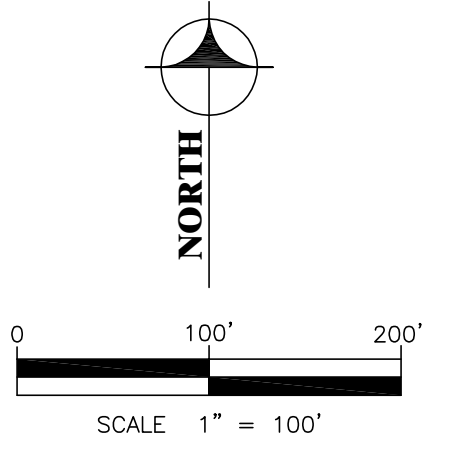
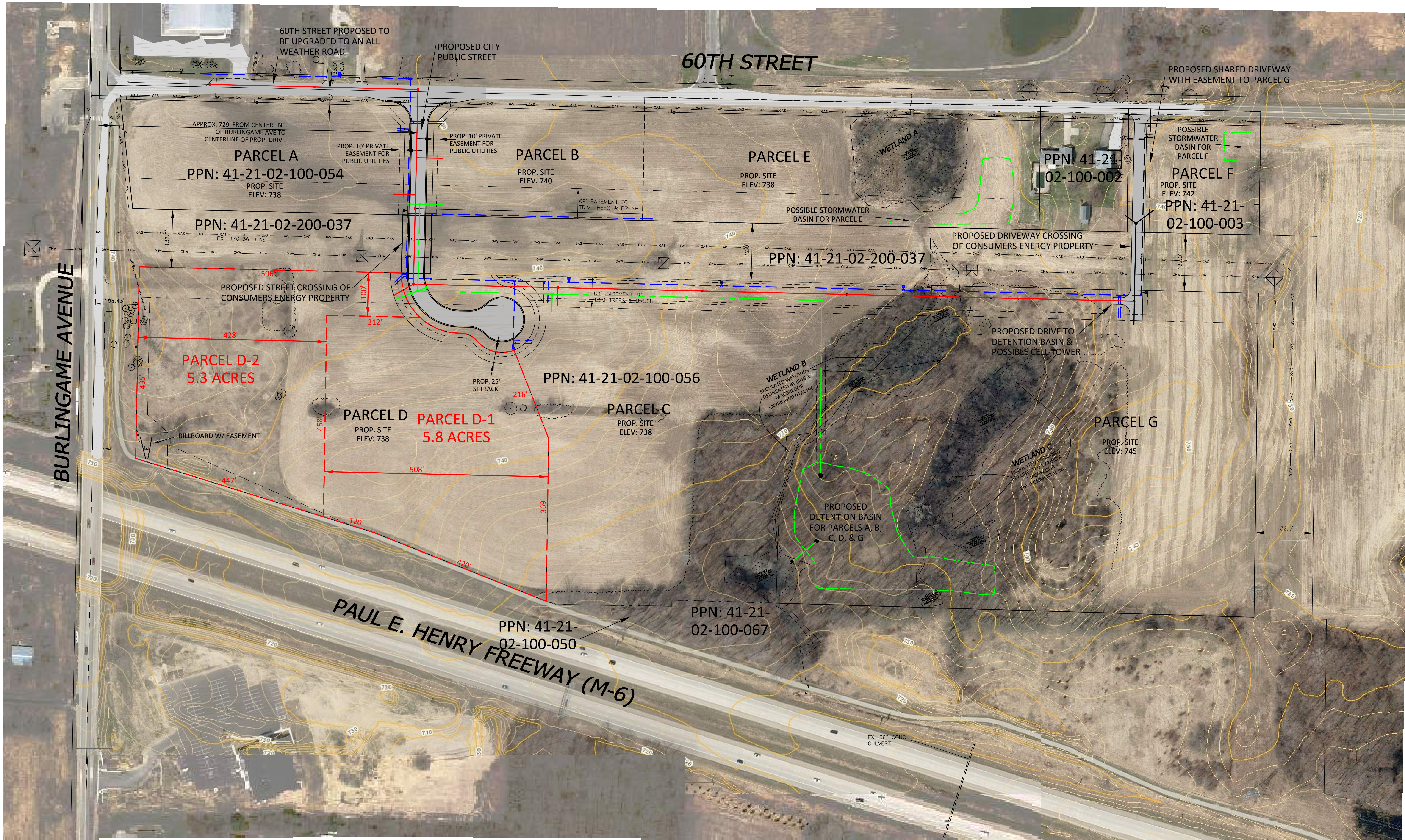

1. PHASE I INCLUDES THE PROPOSED STREET, UPGRADING 60TH STREET AT LEAST TO THE EAST LINE OF PARCEL B, UTILITIES TO PARCELS A, B, C, & D AND THE DETENTION BASIN FOR PARCELS A, B, C, & D.
2. THE PROPOSED DETENTION BASIN ON PARCEL G WOULD BE DESIGNED TO HANDLE PARCELS A, B, C, D & G.
3. PARCELS E & F WOULD BUILD SEPARATE STORMWATER BASINS FOR EACH PARCEL AS PART OF THEIR OWN DEVELOPMENT.
4. WETLAND DELINEATION BY KING AND MACGREGOR.
5. WETLANDS A MAY NOT BE REGULATED.

PREPARED BY:  
**Pathfinder**  
Engineering, Inc.

2335 Byron Center Ave. S.W. Wyoming, MI 49519  
Phone 1-616-878-3885 Fax 1-616-878-4559

REV: 7-11-17  
REV: 8-3-17

DATE: 1-18-17 PROJECT NO.: 16014

COPYRIGHT © 2016 PATHFINDER ENGINEERING, INC. ALL RIGHTS RESERVED. NO PLANS MAY BE REPRODUCED OR TRANSMITTED IN ANY FORM OR BY ANY MEANS, ELECTRONIC OR MECHANICAL, INCLUDING PHOTOCOPYING, RECORDING, OR ANY INFORMATION STORAGE AND RETRIEVAL SYSTEMS, WITHOUT THE EXPRESS WRITTEN CONSENT OF PATHFINDER ENGINEERING, INC.  
S:\16014\dwg\16014 DEV 8-2-17.dwg 8/3/2017 9:21:55 AM EDT

**GABLE HOLDINGS II  
PRELIMINARY  
DEVELOPMENT PLAN**  
6156 BURLINGAME AVENUE  
CITY OF WYOMING, MI

RESOLUTION NO. \_\_\_\_\_

RESOLUTION TO APPROVE THE APPLICATION OF  
AGROPUR, INC. LOCATED AT 5252 CLAY AVE SW,  
FOR AN INDUSTRIAL FACILITIES EXEMPTION CERTIFICATE  
IN THE CITY OF WYOMING

WHEREAS:

1. The City established Industrial Development District Number 159, under Act 198, Public Acts of 1974, as amended, by adopting Resolution Number 13748 on September 16, 1991.
2. Agropur, Inc has filed an application for an Industrial Facilities Exemption Certificate under PA 198 of 1974, with respect to modifying their facility located within Industrial Development District 159, with an estimated cost of \$2,900,000 for real property to be located at 5252 Clay Ave SW.
3. Before acting on this application, the City Council held a public hearing on February 5, 2018, in the Council Chambers, City Hall, 1155 28<sup>th</sup> Street SW, Wyoming, Michigan, at 7:01 p.m., at which hearing the applicant, the Assessor, and a representative of the affected taxing units were afforded an opportunity to be heard on this application.
4. Construction had not begun earlier than six (6) months before December 19, 2017, the date of acceptance of the application for the Industrial Facilities Exemption Certificate.
5. Completion of the facility is calculated to and will, at the time of issuance of the certificate, have the reasonable likelihood to retain, create or prevent the loss of employment in the City of Wyoming.
6. The aggregate SEV of real and personal property exempt from ad valorem taxes within the City of Wyoming, after granting this certificate, will not exceed 5% of an amount equal to the sum of SEV of the unit, plus SEV of personal and real property thus exempted.

NOW, THEREFORE, BE IT RESOLVED:

1. The Wyoming City Council finds and determines that the granting of the Industrial Facilities Exemption Certificate considered together with the aggregate amount of certificate previously granted and currently in force under PA 198 of 1974, as amended and PA 225 of 1978, as amended shall not have the effect of substantially impeding the operation of the City of Wyoming, or impairing the financial soundness of a taxing unit which levies ad valorem property taxes in the City of Wyoming.
2. The application from Agropur, Inc. for an Industrial Facilities Exemption Certificate, with respect to modification of the facility on the following described parcel of real property situated within Industrial Development District 159, to wit:

**Address:** 5252 Clay Ave SW

**Tax Parcel No.:** 41-17-36-128-008

**Legal Description:**

Y1189-1: THAT PART NE 1/4 NW 1/4 LYING N OF N LINE OF PLAT OF FISHER STATION & W OF W LINE OF PENN CEN RR R/W /100 FT WIDE/ & E OF FOL DESC LINE - COM AT INT OF N LINE OF SD PLAT & CL OF MAPLE AVE TH NWLY 383.55 FT ALONG A 549.5 FT RAD CURVE TO LT /LONG CHORD BEARS N 20D W 375.88 FT/ TH N 40D W 337.06 FT TH NWLY ALONG A 687.81 FT RAD CURVE TO RT /LONG CHORD BEARS N 20D 01M 30S W 469.92 FT/ TO PT ON ENDING ON N SEC LINE SEC 36 T6N R12W 7.70 A.

be the same as hereby approved.

3. The Industrial Facilities Exemption Certificate, when issued, shall remain in force for a period of twelve (12) years.

Moved by Councilmember:  
Seconded by Councilmember:  
Motion Carried        Yes  
                                  No

I hereby certify that the foregoing Resolution was adopted by the City Council for the City of Wyoming, Michigan at a regular session held on February 5, 2018.

---

Kelli A. VandenBerg, Wyoming City Clerk

ATTACHMENTS:  
Staff Memo  
IFT Agreement (excerpt)

Resolution No. \_\_\_\_\_

**STAFF REPORT**

Date: January 10, 2018

Subject: Agropur Inc., 5252 Clay Ave SW

From: Jennifer Stowell, Administrative Assistant to the City Manager

Meeting Date: February 5, 2018

---

Recommendation:

Staff recommends a twelve (12) year IFT abatement be granted to Agropur Inc., based on the City of Wyoming’s Economic Development Policy.

Sustainability Criteria:

Environmental Quality – Agropur Inc. has proven to be responsible and cooperative in their efforts to be environmentally responsible. Furthermore, approval of the expansion on this industrial site is consistent with the City’s Land Use Plan.

Social Equity – Approval of this application does not significantly impact social equity.

Economic Strength – Approval of this application will help retain and expand a local industrial company, encourage continued investment by Agropur Inc. and provide additional employment opportunities to the area.

Discussion:

Agropur Inc. has conducted business in the City of Wyoming for nine years and is requesting the approval of an Industrial Facilities Exemption Certificate (IFT). Staff has reviewed the IFT application, which is summarized below by facility:

Address of project:	5252 Clay Ave SW Wyoming, MI 49548
Personal Property:	\$ 0.00
Real Property:	\$ 2,900,000.00
Estimated Jobs:	62 new jobs 161 retained jobs
Starting date of project:	January, 2018

### Project Summary:

Agropur Inc. has done business in Wyoming for nine years and manufactures aseptic beverages. They are renovating their building to increase production capacity and allow the company to modernize certain steps of the production line, notably packaging, attracting new clients for the facility's co-packing business and create new jobs in Wyoming. The project is expected to add additional production volume to the facility of 10.7 million gallons of additional protein-based drinks along with an additional 62 jobs. At full capacity this investment should generate revenues of close to \$83 million.

### Budget Impact:

The estimated first year tax savings for Agropur Inc. which is located in the Kelloggsville school district, is \$35,824.00.

## INDUSTRIAL FACILITIES TAX ABATEMENT AGREEMENT

This Industrial Facilities Tax Abatement Agreement is made as of February 5, 2018 between the City of Wyoming, a Michigan municipal corporation the address of which is 1155 – 28<sup>th</sup> Street SW, PO Box 905, Wyoming, MI 49509-0905 (the “City”) and Agropur, Inc. a corporation, the address of which is 5252 Clay Ave SW, Wyoming, MI 49548 (the “Company”).

### RECITALS

- A. Pursuant to 1974 PA 198, as amended, MCL 207.551 *et seq.* (“Act 198”), the City Council may, after a public hearing, approve an application for an industrial facilities exemption certificate.
- B. Act 198 also requires a written agreement between the City and the Company.
- C. This Agreement is intended to ensure that the industrial facilities exemption certificate will result in the employment and tax base enhancements that provided the reasons for the City Council to approve it and that the certificate, once granted, will not impair the soundness of any taxing unit whose tax revenues will be affected by the granting of the certificate.
- D. The Company filed an application for an Industrial Facilities Tax Abatement pursuant to Act 198 a copy of which is attached as Exhibit A and incorporated by reference (the “Application”).
- E. Following a public hearing on February 5, 2018 the City Council adopted a resolution to approve the issuance of an industrial facilities exemption certificate for a period of 12 years for the property located at 5252 Clay Ave SW, in the City (the “Site”) conditional upon the parties entering into this Agreement (the “Tax Abatement”).
- F. The City Council did so upon the Company’s representations in the Application and upon the understanding that doing so would enhance the City’s employment and tax base as indicated in the application and as stated at the public hearing which enhancements would exceed the term of the Tax Abatement.

### TERMS AND CONDITIONS

In exchange for the consideration in and referred to by this Agreement, the parties agree:

- 1. The Company affirms the statements in the application and the statements at the public hearing that it will invest not less than \$2,900,000 in improvements to its property in the City and that at least 62 new job(s) will be created at the Site and at least 161 jobs will be retained at the Site as a result of that investment. The Company further pledges that those improvements will remain in place at the Site or be replaced by comparably valued improvements for at least 2 years after the expiration of the term of the Tax Abatement and the jobs created and maintained will remain at the Site for at least 2 years after the expiration of the term of the Tax Abatement.
- 2. The City is relying upon, and the Company agrees the City may rely upon, the representations in the preceding paragraph, in the Application, and at the public hearing, for purposes of determining the length of the Abatement, the amount of the Abatement, and other terms of the Abatement.
- 3. Beginning on December 31 of the year which is 2 years after the Abatement is granted (*i.e.*, 2020) and each December 31 thereafter the Company shall submit a letter to the City, stating:
  - (a) The number of new jobs projected in the Application to be created and retained at the Site upon the project’s completion and the actual number of new jobs created and retained at the Site.

- (b) The number of employees at the Site at the time of the Application and the current number of employees at the Site.
  - (c) The estimated project cost stated in the Application and the actual project cost.
4. Upon receipt of the letter provided for in the preceding paragraph:
- (a) The City may either:
    - (1) Apply the criteria in the City's Act 198 Tax Abatement Policy in effect as of the date of this Agreement and increase or decrease the term of the Tax Abatement to the maximum number of years allowable under that Policy based on the Company's actual employment levels at the Site and project costs as stated in the letter, or
    - (2) If the number of new jobs at the Site or the cost of the project is substantially below that stated in the Application, the City Council may recommend revocation of the Tax Abatement.
  - (b) The City may, in its discretion, waive its right to reduce the term of the years of the Abatement or to revoke the Tax Abatement if:
    - (1) The Company has substantially met its stated goals, with only minor deviations which are not expected to reduce the anticipated benefits of the City, or
    - (2) Upon a finding of changed circumstances not reasonably anticipated by the Company at the time it made Application.
  - (c) The City shall provide the Company written notice of and an opportunity to address the City Council prior to formally considering any such actions.
5. The Company intends to continue operations within the City for the time period at least equal to two years beyond the expiration of the term of the Tax Abatement as granted.
- (a) If, at any time during the term of the Tax Abatement or two years following the expiration or early termination of the Tax Abatement, the City determines based on a Company announcement or other reasonably reliable information that the Company is intending to discontinue or substantially curtail its operations at the Site, or the City determines that the Company has discontinued or substantially curtailed its operations at the Site, or the company no longer employs at the Site the number of employees represented in the Application and in this Agreement:
    - (1) The City Council may, in its sole discretion, request revocation of the Tax Abatement; and
    - (2) The City Council, in its sole discretion, may require the Company to pay the City all or any part of an amount equal to the total taxes abated by the City under the Tax Abatement.
  - (b) If, at any time during the term of the Tax Abatement or two years following the expiration or early termination of the Tax Abatement, the Company contends in any appeal taxable value of its property at the Site should be less the Company's cost to acquire the property and construct and install the project plus the value of the property prior to undertaking the project, as reflected in the Application, any certification made by the Company under Act 198, any letters filed with the City pursuant to this Agreement, or any other statements made by or on behalf of the Company in applying for or complying with the terms of the Tax Abatement and this Agreement:
    - (1) The City Council may, in its sole discretion, request revocation of the Tax Abatement; and
    - (2) The City Council, in its sole discretion, may require the Company to pay the City all or any part of an amount equal to the total taxes abated by the City under the Tax Abatement.

(c) In making any decision under the preceding subparagraphs (a) or (b), the City Council shall consider whether:

(1) Due to events or conditions which were unforeseeable by either party on the date of this Agreement, and absent the fault of either party, it has become impossible or commercially impractical for the Company to continue its operation at the Site; or

(2) The Company has substantially complied with all requirements of this Agreement, such that the Company's failure to comply fully with all requirements was neither willful nor intentional, and the City has reasonably received the benefits anticipated from granting the Tax Abatement.

(d) The City shall provide the Company written notice of and an opportunity to address the City Council prior to formally considering any such actions.

6. This Agreement is entered into according to Section 22 of Act 198, as amended, MCL 207.572, is in addition to the other requirements of Public Act 198, and does not modify or waive any requirements of Act 198.

7. This is the entire agreement between the parties as to its subject matter. No unwritten agreements shall have any effect. This Agreement may be modified only with a written agreement signed by both parties following approval of the City Council.

The parties have signed this Agreement as of the date first written above.

CITY OF WYOMING

AGROPUR, INC.

By: \_\_\_\_\_  
Jack A. Poll, Mayor

By: \_\_\_\_\_  
\_\_\_\_\_, \_\_\_\_\_

By: \_\_\_\_\_  
Kelli A. VandenBerg, City Clerk

By: \_\_\_\_\_  
\_\_\_\_\_, \_\_\_\_\_

Date signed: \_\_\_\_\_, 2018

Date signed: \_\_\_\_\_, 2018

RESOLUTION NO. \_\_\_\_\_

RESOLUTION TO AUTHORIZE THE CITY MANAGER TO ENTER INTO  
PURCHASE AGREEMENTS AND REDUCE THE SALES PRICE FOR  
SITE 36 PROJECTS MEETING CERTAIN CRITERIA

WHEREAS:

1. The City of Wyoming (the "City") and the Brownfield Redevelopment Authority of the City of Wyoming (the "Authority") entered into a Development Agreement dated as of October 3, 2016, with Franklin Partners, L.L.C. ("Franklin Partners") for the redevelopment of the parts of Site 36 remaining owned by the Authority (the "Development Agreement").
2. The City and the Authority have previously extended the Development Agreement.
3. The Development Agreement set out certain redevelopment goals for Site 36 including (i) a development that is an attractive asset to the City and its immediate vicinity, (ii) quality, family-supporting jobs and tax base, and (iii) appropriate use of Site 36's industrial amenities (*e.g.*, natural gas, electric, City water, City sanitary sewer, road access and other transportation amenities).
4. The Development Agreement currently requires City Council and Authority Board approval of any proposed sale and development of Site 36 property.
5. Franklin Partners has actively engaged in communications with a number of entities regarding possible purchase of portions of Site 36 and has requested (i) that the City and Authority specify acceptable development criteria, (ii) because some prospective purchasers have indicated a need for a binding purchase agreement before their project is publicly discussed, that the City and Authority authorize the City Manager to sign a binding agreement if the proposed development and use meets certain criteria, and (iii) that agreement to provide for adjustments in the sale price, commissions, or other arrangements needed to make the transaction acceptable to all parties.
6. The City Council finds such an approach to be meritorious in order to maximize the public benefit from the redevelopment and reuse of Site 36.

NOW, THEREFORE, BE IT RESOLVED:

1. If a proposed redevelopment of property that is part of Site 36 meets the following criteria, the City Manager may, without further approval from the City Council or the Authority Board enter into a binding purchase agreement for the sale of that portion of Site 36 and all City officers, staff and agents are authorized and directed to take all actions reasonably needed to consummate that transaction.
  - A. The development will encompass at least 60 acres.
  - B. At least \$100 million will be invested in the development.
  - C. At least 1,000 full-time jobs will result from the development and those full-time employees will all receive health insurance and other benefits.
  - D. Grants, loans, tax increment revenues or other sources of funds will be used to pay any costs incurred by the City to address any infrastructure or other improvements

needed to accommodate the development so that no unreimbursed funds generated by the City's current tax base will be needed to pay those costs.

- E. The improvements on the site will be attractive and comply with the zoning and land use standards applicable to the site and the terms of conveyance will require compliance with the applicable site plan and other land use approval procedures.
  - F. The development and use of the site will comply with all applicable environmental and use requirements including, without limitation, those in the Declaration of Restrictive Covenants, the groundwater use ordinance, and the documents conveying title to the Authority.
  - G. Any adjustments in the sale price, commissions, or other arrangements will still enable the City and the Authority to recover all costs they have incurred related to Site 36 from their first engagement in efforts to ensure its redevelopment through the closing and provide a suitable balance to pay any costs they incur after closing that will not be reimbursed by tax increment revenues.
  - H. Any agreements shall be in a form and substance acceptable to the City Manager and the City and Authority's legal counsel, and ensure compliance with the requirements in this resolution.
2. All resolutions and parts of resolutions are, to the extent of any conflicts with this resolution, rescinded.

Moved by Councilmember:

Seconded by Councilmember:

Motion carried        Yes  
                                  No

I certify that the foregoing Resolution was adopted by the City Council of the City of Wyoming, Michigan at a regular meeting held on February 5, 2018.

Date: February \_\_, 2018

\_\_\_\_\_  
Kelli A. VandenBerg, Wyoming City Clerk

Resolution No. \_\_\_\_\_

RESOLUTION NO. \_\_\_\_\_

A RESOLUTION TO APPROVE AN AMENDMENT TO  
SECTION 9.1(f) OF THE CHARTER OF THE CITY OF WYOMING  
TO RENEW THE PUBLIC SAFETY MILLAGE FOR THE CITY OF WYOMING

WHEREAS, Section 9.1 of the Charter of the City of Wyoming provides as follows:

**Sec. 9.1. Power to tax: tax limit.**

The City shall have the power to assess taxes and levy and collect rents, tolls and excises. Exclusive of any levies authorized by statute to be made beyond charter tax rate limitation, the annual ad valorem tax levy shall not exceed one-half percent of the valuation of all real and personal property subject to taxation in the City, except that an additional two-tenths of one percent, 2 mills on the dollar, may be levied for sewer, water and street improvements, but this latter shall in no way be construed as limitation on the issuance of bonds for water or sewer purposes. An additional thirty-nine thousandths (39/1000) of one percent, 0.39 mills on the dollar, or less, may be levied annually for the operation, maintenance and any other expenses for the public library in Wyoming.

- (a) *Sidewalk snowplowing and maintenance levy.* The city shall have the power to levy an additional 2/100 of one percent, 0.2 mills on the dollar for the purpose of snowplowing sidewalks and to repair and construct sidewalks within the city.
- (b) *Public transportation levy.* An additional twenty-five thousandths (25/1000) of one percent (1%), a 0.25 mills on the dollar, or less, may be levied annually for use for public transportation. (This subsection shall expire on June 30, 2000).
- (c) *Parks, recreation and senior citizens centers levy.* An additional fifteen-hundredths of one percent, 1.5 mills on the dollar, or less, may be levied annually for use for the operation, maintenance and any other expenses for parks, recreation and senior citizens centers.
- (d) *Fire department levy.* An additional seventy-five-thousandths of one percent, 0.75 mills on the dollar, may be levied annually for the operation, maintenance and other expenses of the Fire Department.
- (e) *Police department levy.* An additional one hundred-twenty-five-thousandths of one percent, 1.25 mills on the dollar, may be levied annually for the operation, maintenance and other expenses of the Police Department.
- (f) *Public Safety levy.* An additional one hundred twenty-five thousandths of one percent, 1.25 mills on the dollar, may be levied annually for public safety for the operation, maintenance and administration of police and fire services. (This subsection shall expire on June 30, 2020).

WHEREAS, the current public safety levy will expire on June 30, 2020 and renewal of that levy is necessary to continue the proper operation of the Public Safety Department, Now Therefore,

BE IT RESOLVED that Section 9.1(f) of the Charter of the City of Wyoming is hereby amended to read as follows:

(f) *Public Safety levy.* An additional one hundred-twenty-five thousandths of one percent, 1.25 mills on the dollar, may be levied annually for public safety for the operation, maintenance and administration of police and fire services.

BE IT FURTHER RESOLVED:

1. That the form in which the proposed Charter Amendment shall be printed to appear on the ballot of the election to be held on August 7, 2018, shall be as follows:

“PROPOSAL TO RENEW PUBLIC SAFETY MILLAGE”

“Shall Section 9.1 (f) of the Charter of the City of Wyoming be renewed to provide for an annual levy of 1.25 mills on the dollar for public safety for operation, maintenance and administration of police and fire services in the City of Wyoming? This is a permanent renewal. The amount of revenue raised by the levy in the first year is estimated at \$2,519,841.

2. The City Clerk shall submit a certified copy of this resolution to the governor and to the Attorney General of the State of Michigan for approval as required by law.

3. That before submission of the proposed amendment to the electors, the City Clerk shall publish the full text of the proposed amendment to Section 9.1 of the Charter and the full text of the existing Charter provision in at least one edition of a newspaper meeting the requirements of Section 17.9 of the City Charter.

Moved by Councilmember:

Seconded by Councilmember:

Motion Carried        Yes  
                                      No

I hereby certify that the foregoing Resolution was adopted by the City Council for the City of Wyoming, Michigan at a regular session held on February 5, 2018.

\_\_\_\_\_  
Kelli A. VandenBerg, Wyoming City Clerk

Resolution No. \_\_\_\_\_

RESOLUTION NO. \_\_\_\_\_

TO AUTHORIZE THE WRITE-OFF OF  
DELINQUENT 2011 CITY PROPERTY TAXES

WHEREAS:

1. Delinquent personal property taxes remain outstanding for the 2011 tax year.
2. Per Public Act 206 (Property Tax Act) of the State of Michigan, delinquent personal property taxes that have been outstanding five years or more may be written off.
3. The City Treasurer's Office has made a diligent attempt to collect the outstanding balances and believes that the delinquent amounts will not be recovered.
4. The City Treasurer's Office is requesting City Council to approve the write-off of \$1,576.09 in delinquent 2011 personal property ad valorem taxes.

NOW, THEREFORE, BE IT RESOLVED:

1. The Wyoming City Council hereby authorizes the write-off of \$1,576.09 in delinquent 2011 personal property taxes.

Moved by Councilmember:

Seconded by Councilmember:

Motion Carried      Yes  
                                    No

I hereby certify that the foregoing Resolution was adopted by the City Council for the City of Wyoming, Michigan at a regular session held on February 5, 2018.

\_\_\_\_\_  
Kelli A. VandenBerg, Wyoming City Clerk

ATTACHMENTS:

Staff Report

2011 Delinquent Personal Property Tax List

## STAFF REPORT

From: Andrea Boot, Treasurer's Office  
Date: January 30, 2018  
Subject: Write-off of 2011 Delinquent Personal Property Taxes  
Meeting Date: February 05, 2018 Council Meeting

---

### Recommendation:

Staff recommends that the City Council approves the write-off of 2011 delinquent personal property taxes in the amount of \$1,576.09 pursuant to Public Act 206 (Property Tax Act)

### Sustainability Criteria:

Environmental Quality – Does not significantly impact this criterion.

Social Equity – Does not significantly impact this criterion.

Economic Strength – Does not significantly impact this criterion.

### Discussion:

According to PA 206 (Property Tax Act) 211.56a, delinquent personal property taxes may be written off after being delinquent for five years. The write-off procedure requires a resolution from each taxing jurisdiction granting its permission. I am seeking permission to write off the delinquent 2011 City ad valorem taxes in the amount of \$1,576.09. An itemized listing is attached for your reference. Once City Council has passed a resolution, the documentation must be approved by the District Court. Rather than burden the Court with petitions from each jurisdiction, the Kent County Treasurers Association compiles the resolutions from each unit and presents it as one approval by the Judge.

### Budget Impact:

This write-off will reduce the overall City tax revenue by \$1,576.09.

01/15/2018  
12:18 PM  
By: boota

DELINQUENT TAXES LEFT TO PAY FOR CITY OF WYOMING

Page: 1/1  
DB: Wyoming

Tax Year: 2011 Calculated As of: 12/31/2017  
POPULATION: All Records

Owner Parcel #	Tax Year	Tax Due	Intrst Due	Admin Due	Penalty	Other Fees	Total Due
ALVAN MOTOR FREIGHT PO BOX 757 Ortonville MI 48462 41-50-93-053-500	2011	1,847.96	315.98	18.47	9.61	0.00	2,192.02
CAFE 24 SEVEN 2763 44TH ST SW WYOMING MI 49519 41-50-93-985-370	2011	444.85	39.69	4.44	0.61	0.00	489.59
TINA'S NAILS 1851 44TH ST SW WYOMING MI 49509 41-50-93-985-639	2011	52.28	4.65	0.51	0.07	0.00	57.51
JIMMY JOHN'S 1851 44TH ST SW WYOMING MI 49509 41-50-93-985-640	2011	274.71	24.52	2.74	0.38	0.00	302.35
STUDIO 5 PO BOX 151 JENISON MI 49429 41-50-93-985-761	2011	594.11	55.93	5.93	0.95	0.00	656.92
CREATIVE SALES GROUP INC 3761 EASTERN AVE SE WYOMING MI 49508 41-50-93-986-000	2011	106.88	18.28	1.06	0.56	0.00	126.78
ECLECTIC EATERY 15 44TH ST SW WYOMING MI 49509 41-50-93-986-300	2011	11.60	8.12	0.11	0.35	0.00	20.18
WORLD TV SATELLITE 1600 CHICAGO DR SW WYOMING MI 49509 41-50-93-986-318	2011	192.48	16.51	1.91	0.23	0.00	211.13
HELMS CAULKING-MERCURY BUILDIN 2348 BURTON ST SW WYOMING MI 49509 41-50-93-987-040	2011	432.04	41.10	4.31	0.71	0.00	478.16
GOURMET TO GO VENDING 4767 BROADMOOR AVE #7 GRAND RAPIDS MI 49512 41-50-93-987-096	2011	46.95	8.02	0.46	0.24	0.00	55.67
ROBOCAM INC 4301 CLYDE PARK AVE SW WYOMING MI 49509 41-50-93-995-400	2011	387.02	63.53	3.86	1.89	0.00	456.30
SECURITY ASSOC INTL 2101 S ARLINGTON HEIGHTS RD ARLINGTON HTS IL 60005 41-50-93-995-605	2011	61.02	5.44	0.60	0.08	0.00	67.14
RIO GRAND STEAKHOUSE 1820 44TH ST SW WYOMING MI 49519 41-50-93-997-390	2011	1,099.12	98.09	10.98	1.51	0.00	1,209.70
2011	13	5,551.02	699.86	55.38	17.19	0.00	6,323.45
DLQ PARCEL COUNT	13	5,551.02	699.86	55.38	17.19	0.00	6,323.45

RESOLUTION NO. \_\_\_\_\_

RESOLUTION TO AUTHORIZE THE MAYOR AND CITY CLERK TO ACCEPT A  
DONATION OF FUNDS FROM THE WYOMING SENIOR FELLOWSHIP CLUB, INC.  
AND TO AUTHORIZE THE RELATED BUDGET AMENDMENT

WHEREAS:

1. The Wyoming Senior Fellowship Club (WSFC) is a nonprofit affiliate of the City of Wyoming chartered to support the City's Wyoming Senior Center (WSC), located at 2380 DeHoop Ave, SW, Wyoming, Michigan.
2. The WSC is in need of a new copier, which the City, as a government entity, can purchase at an exceptional value from a national bid in the amount of \$5,935.
3. The WSFC has agreed to donate funds to the City for its purchase.
4. This purchase was not planned in the City's WSC budget and as such the creation of a capital account line item must be authorized by the City Council and the FY 2018 budget amended.

NOW, THEREFORE, BE IT RESOLVED:

1. The City Council does hereby accept the donation of \$5,935 from the Wyoming Senior Fellowship Club.
2. The City Council does hereby authorize the attached budget amendment.

Moved by Councilmember:

Seconded by Councilmember:

Motion Carried        Yes  
                                  No

I hereby certify that the foregoing Resolution was adopted by the City Council for the City of Wyoming, Michigan at a regular session held on February 5, 2018.

ATTACHMENTS:  
Budget Amendment  
WSFC Correspondence

\_\_\_\_\_  
Kelli A. VandenBerg, Wyoming City Clerk

Resolution No. \_\_\_\_\_



January 18, 2018

Rebecca Rynbrandt, Director of Community Services  
City of Wyoming  
1155 – 28<sup>th</sup> St SW  
Wyoming, MI 49509

Dear Rebecca:

I am pleased to inform you that the Wyoming Senior Fellowship Club has voted in the affirmative (by a tally of 52 votes to 1 votes) to approve the Club's Finance Committee's unanimous recommendation of financial support up to \$5,935.00 for the proposed copy machine at the Wyoming Senior Center, 2380 DeHoop SW.

If you have any questions, please feel free to contact me.

Sincerely,

A handwritten signature in black ink that reads "Jack Lowe". The signature is written in a cursive style with a large, sweeping initial "J".

Jack Lowe, President  
Wyoming Senior Fellowship Club

RESOLUTION NO. \_\_\_\_\_

RESOLUTION TO AUTHORIZE THE MAYOR AND CITY CLERK  
TO EXECUTE A HELIPAD LICENSE AGREEMENT WITH  
METRO HEALTH – UNIVERSITY OF MICHIGAN HEALTH

WHEREAS:

1. As detailed in the attached agreement, Metro Health – University of Michigan Health requests the use of a portion of the parking lot at the Fire Training Center located at 2300 Gezon Parkway.
2. The helipad will meet all necessary requirements in connection with emergency and hospital operations of Metro Health – University of Michigan Health located at 5900 Byron Center Ave SW.
3. It is recommended the City Council accept the Agreement.

NOW, THEREFORE, BE IT RESOLVED:

1. The City Council does hereby authorize the Mayor and City Clerk to execute a Helipad License Agreement with Metro Health – University of Michigan Health.

Moved by Councilmember:

Seconded by Councilmember:

Motion Carried        Yes  
                                  No

I hereby certify that the foregoing Resolution was adopted by the City Council for the City of Wyoming, Michigan at a regular session held on February 5, 2018

ATTACHMENT:  
Agreement

\_\_\_\_\_  
Kelli A. VandenBerg, Wyoming City Clerk

Resolution No. \_\_\_\_\_

## HELIPAD LICENSE AGREEMENT

**THIS HELIPAD LICENSE AGREEMENT** (this “Agreement”) is made this \_\_\_\_ day of \_\_\_\_\_, 201\_ by and between **METRO HEALTH – UNIVERSITY OF MICHIGAN HEALTH**, a Michigan nonprofit corporation having an address of 5900 Byron Center Ave SW, Wyoming, MI 49519 (“Licensee”), and **CITY OF WYOMING**, a Michigan municipal corporation having an address at 1155 28<sup>th</sup> Street SW, Wyoming, MI 49509 (“Licensor”).

Licensee desires to use a portion of the parking lot of the City of Wyoming Fire Training Center legally described on Exhibit A, at 2300 Gezon Parkway, Wyoming, Michigan (“Parking Lot”) for air ambulance operations, including without limitation ingress and egress for ambulances, emergency vehicles and personnel through the Fire Station and Fire Training Center driveways, and an approximately 100’x100’ helipad with lighting, signage, wind cones, touchdown and liftoff area, final approach and takeoff area, and markings for air ambulance operations (altogether “Helipad”), for use and access by Licensee and Licensee’s employees, contractors, maintenance providers, and patients, and by ambulance providers, medical staff/physicians/emergency medical providers, helicopter providers and helicopter pilots (individually and collectively “Licensee and Guests”) in connection with operation of Licensee’s emergency and hospital operations at Metro Health – University of Michigan Health Hospital, located nearby at 5900 Byron Center Ave SW, Wyoming, Michigan. Licensor is willing to grant a license for the Helipad upon the terms of this Agreement.

**NOW, THEREFORE**, for valuable consideration, receipt of which is acknowledged, Licensor and Licensee, agree as follows:

1. **HELIPAD/INGRESS AND EGRESS.** On the terms and conditions of this Agreement, Licensor grants an exclusive license to Licensee to construct/reconstruct, improve, seal, light, mark, access, use, operate, and maintain the Helipad upon the Parking Lot at Licensee’s own cost, to access and use the lighting available at the Parking Lot, and to access and use the Parking Lot and related driveways designated by Licensor from time to time for vehicular and pedestrian ingress and egress of Licensee and Guests between the Helipad and Gezon Parkway. Licensee is also authorized at Licensee’s cost to implement typical or required safety and security measures related to helicopter use, touchdown and takeoff, such as (without limitation): (a) to temporarily block entry to the Parking Lot and clear obstacles and onlookers when a helicopter touchdown/takeoff is occurring or expected, during patient transfer, and during the interim time the helicopter is on the Helipad, (b) to install temporary or permanent fencing, landscaping, equipment storage facilities, and/or signage approved in advance by Licensor (the parties will discuss and evaluate fencing or barrier needs for West and South boundaries after 120 days of use), (c) to install and use exterior switches to turn on Parking Lot lighting, (d) to install markers and lights within the Parking Lot including without limitation on buildings, light poles, power lines and obstructions, (e) to use typical means consistent with the aviation industry to clear snow, ice and debris from the Helipad and/or Parking Lot as needed by Licensee. Licensor shall have the right to continue to use the Parking Lot in common with Licensee except when safety and security measures prevent such use, such as during the Helipad use, touchdown, or takeoff of a helicopter.

2. **COORDINATION PLAN.** Licensee and Licensor will cooperate to establish and update from time to time a coordination plan for operation of the Helipad, including for patient transfers. Each shall designate a primary contact to coordinate communications among them, including notices of air ambulance touchdowns and takeoffs and concerns arising from time to time. Licensee shall be responsible to secure the Helipad during touchdowns and takeoffs by Licensee and Guests, in a manner consistent with reasonable industry practices for helipads of similar size, rating, use location, and characteristics. The Helipad has been designed to the requirements of a specific helicopter and is not set up for public use. No one other than Licensee and Guests is authorized to use the Helipad for touchdowns, takeoffs or any other helicopter operations, except in the case of a disaster, terrorist act, or state of emergency requiring a massive coordinated public health response, in which case use is at the sole risk of the user, the user shall be solely responsible for absolutely every aspect of its use and operation, including without limitation safety, security, lighting, coordination, operation, flight, touchdown and takeoff, Helipad condition, weather, obstructions, determining suitability of the Helipad for its helicopter and use, compliance with all applicable laws, rules, and regulations, and any damage, injury or death.

3. **MAINTENANCE.** Licensor shall be responsible at its own cost for maintaining the Parking Lot generally for Licensor’s use of the Parking Lot (which is for driveway, parking, and training exercises). Licensee shall be

responsible at Licensee's own cost during the term of this Agreement for any further maintenance desired by Licensee for the purpose intended, such as but not limited to additional clearing of snow and ice, sealing, marking, or de-icing of the Helipad.

4. **TERM.** The term of this Agreement shall commence on \_\_\_\_\_, 201\_ and will not be terminated by Licensor before \_\_\_\_\_, 201\_ (one year after that commencement date). After \_\_\_\_\_, 201\_, either Licensor or Licensee can terminate this Agreement for any reason upon ninety (90) days' written notice to the other party.

5. **REMOVAL/NONREMOVAL OF HELIPAD.** If Licensor provides notice to Licensee within thirty (30) days of termination of this Agreement requesting the Helipad to be removed, then Licensor shall cause the Helipad to be returned substantially to the condition that existed on the date of this Agreement, once the weather reasonably permits such work to be undertaken safely and efficiently. Alternatively, Licensor may decide to retain the Helipad and to maintain it following termination of this Agreement.

6. **INSURANCE.** During the term of this Agreement, each of Licensor and Licensee shall carry public liability and property damage insurance or self-insurance as to the Parking Lot, naming the other as additional insured, in the minimum amount of \$1,000,000 per occurrence, and \$3,000,000.00 in the aggregate, and shall provide a certificate of insurance evidencing such coverage upon request. To the extent that a loss is covered by insurance in force and recovery is made from such loss, Licensor and Licensee hereby mutually release each other from liability and waive all rights of subrogation and rights of recovery against each other for any loss from perils insured against under their respective insurance policies (including extended coverage), provided that this waiver shall not be applicable if it has the effect of invalidating any insurance coverage of Licensor or Licensee.

7. **NO REFERRALS.** The parties acknowledge that there is good and valuable consideration in support of the covenants made in this Agreement. The parties acknowledge and agree that the consideration has not been determined in a manner that takes into account the volume or value of any referrals or other business generated between the parties, does not involve payment for referrals for medical services, and would be commercially reasonable irrespective of whether any referrals are ever made between the parties.

8. **BINDING EFFECT/AMENDMENT.** The terms and conditions contained in this Agreement shall bind and inure to the benefit of Licensor and Licensee, and their respective successors and assigns. This Agreement may not be amended except pursuant to a written instrument executed by Licensor and Licensee.

**WHEREFORE**, the parties hereto have executed this Agreement as of the day and year first above written.

**LICENSOR:  
CITY OF WYOMING**

By: \_\_\_\_\_

Its: \_\_\_\_\_

By: \_\_\_\_\_

Its: \_\_\_\_\_

**APPROVED AS TO FORM:**

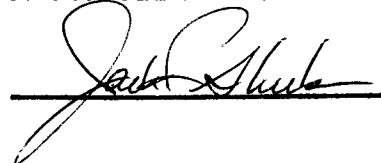
  
\_\_\_\_\_

**LICENSEE:  
METRO HEALTH –UNIVERSITY OF MICHIGAN HEALTH**

By: \_\_\_\_\_

Its: \_\_\_\_\_

**EXHIBIT A**

Land situated in the City of Wyoming, County of Kent, State of Michigan legally described as:

PART OF SW 1/4 COM AT W 1/4 COR TH S 0D 14M 59S E ALONG W SEC LINE 667.45 FT TO S LINE N 1/2 N 1/2 SW 1/4 TH S 88D 12M 56S E ALONG SD S LINE 340.0 FT TO BEG OF THIS DESCRIPTION - TH N 0D 14M 59S W 622.06 FT TO SLY LINE OF GEZON PKWY TH N 89D 13M 43S E ALONG SD SLY LINE 68.57 FT TH SELY 441.02 FT ALONG A 655.0 FT RAD CURVE TO RT /LONG CHORD BEARS S 68D 53M 04S E 432.74 FT/ TH S 0D 14M 59S E 481.79 FT TO S LINE N 1/2 N 1/2 SW 1/4 TH N 88D 12M 56S W ALONG SD S LINE 471.86 FT TO BEG \* SEC 34 T6N R12W 6.35 A.

Parcel # 41-17-34-300-022  
2300 Gezon Parkway, Wyoming, Michigan

RESOLUTION NO. \_\_\_\_\_

RESOLUTION TO AUTHORIZE PAYMENT TO  
GRAND ELK RAILROAD, INC., FOR ANNUAL MAINTENANCE OF  
TRAFFIC CONTROL DEVICES AT RAILROAD CROSSINGS  
IN THE CITY OF WYOMING

WHEREAS:

1. Grand Elk Railroad owns railroad tracks within the City of Wyoming, crossing several major streets which require the use of proper traffic control devices.
2. On December 21, 2012, the State of Michigan passed Act 421 which requires that all road authorities participate in the annual maintenance cost of railroad crossings with active traffic control devices.
3. The rate per crossing is established in Act 421 depending on the various traffic control devices at each location.
4. Grand Elk Railroad, Inc., has completed maintenance of these traffic control devices for calendar year 2017, and has submitted an invoice to the City of Wyoming in the amount of \$19,350 for reimbursement.
5. It is recommended that City Council authorize payment to Grand Elk Railroad, Inc., for the cost of annual maintenance on its control devices in the amount of \$19,350.
6. This cost can be funded out of the major street fund, account number 202-441-47400-930.000.

NOW, THEREFORE, BE IT RESOLVED:

1. That City Council does hereby authorize payment to Grand Elk Railroad, Inc., for annual maintenance of traffic control devices at railroad crossings in the amount of \$19,350.

Moved by Councilmember:

Seconded by Councilmember:

Motion Carried        Yes  
                                  No

I hereby certify that the foregoing Resolution was adopted by the City Council for the City of Wyoming, Michigan at a regular session held on February 5, 2018.

\_\_\_\_\_  
Kelli A. VandenBerg, Wyoming City Clerk

ATTACHMENTS:

Staff Report  
Invoice

Resolution No. \_\_\_\_\_

## STAFF REPORT

DATE: January 30, 2018

SUBJECT: Authorize Payment to Grand Elk Railroad, Inc.

FROM: Russ Henckel, Assistant Director of Public Works – Engineering

Date of Meeting: February 5, 2018

---

### RECOMMENDATION:

It is recommended that City Council authorize payment to Grand Elk Railroad, Inc., in the amount of \$19,350 for the cost of annual maintenance on its control devices for the 2017 calendar year.

### SUSTAINABILITY CRITERIA:

#### Environmental Quality

Does not impact this criterion.

#### Social Equity

Traffic control devices are provided and maintained at railroad crossings throughout the City by the railroad without regard to income level or socio-economic status.

#### Economic Strength

Proper maintenance of traffic control devices at railroad crossings will decrease the amount of traffic congestion and travel time throughout the City.

#### Quality Service Impact

Regular maintenance of railroad signals at signalized crossings maintains optimal traffic flow and increases safety.

### DISCUSSION:

Grand Elk Railroad owns railroad tracks within the City of Wyoming, crossing several major streets which requires the use of proper traffic control devices including flashing signals and cantilever arms. On December 21, 2012, the State of Michigan passed Act 421 which requires that all road authorities participate in the annual maintenance cost of railroad crossings with active traffic control devices. The rate per crossing is established in Act 421 depending on the various traffic control devices at each location. Grand Elk Railroad, Inc., has completed maintenance of these traffic control devices for calendar year 2017, and has submitted an invoice to the City of Wyoming in the amount of \$19,350 for reimbursement.

### BUDGET IMPACT:

Sufficient funds are available in the major street traffic services repairs and maintenance account, 202-441-47400-930.000.

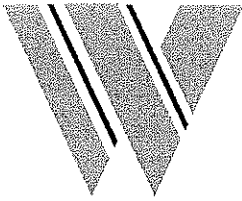

Grand Elk Railroad, Inc.  
 315 West 3rd Street  
 Pittsburg KS 66762

# Invoice

**WATCO**  
 COMPANIES

For Billing Questions or Disputes Contact:

<b>Information</b>	
Invoice Number	90681242
Invoice Date	01/22/2018
PO No.	2017 Signal Maint
PO Date	
Customer No.	9029
Invoice Amt	19,350.00
<b>Terms of Payment</b>	30 Days
<b>Include Invoice Number with Payment</b>	

**Sold-To-Party**

City of Wyoming  
 1155 28th St. SW  
 Wyoming MI 49509

**Bill-To-Party:**

City of Wyoming  
 1155 28th St. SW  
 Wyoming MI 49509

Additional Billing Comments:

Item	Material Description	Quantity	Unit Price	Total
10	2017-Signal Maint-MCL 462315(3)	1 EA	19,350.00	19,350.00
<b>Total Amount</b>				<b>19,350.00</b>

**Please Remit Check Payments to:**

Grand Elk Railroad, Inc.  
 PO Box 790343  
 BIN # 150077  
 St. Louis, MO 63179-0343

**Please Remit ACH or EFT Payments to:**

BMO Harris Bank  
 ABA# 071000288  
 ACCOUNT# 1430137371  
 ACCT NAME: Watco Companies, L.L.C.



Grand Elk Railroad, Inc  
 315 W 3rd St  
 Pittsburg, KS 66762

<b>Bill-To-Party</b> City of Wyoming 1155 28th St SW Wyoming, MI 49509 accounts payable@wyomingmi.gov	<b>Information</b> Invoice Number Invoice Date Customer No. PO Number Invoice Amount Terms of Payment	2017-Signal Maintenance 1/22/2018 9029 MCL 462315(3) <b>\$ 19,350.00</b> Due Upon Receipt
---	---	--

**Listing of Active Crossing Traffic Control Devices and Road Authority Fee Schedule in Accordance with MCL 462.315(3) - RAILROAD CODE OF 1993 - Act 354 of 1993**

**Current schedule of fees - Effective 12-21-2012**

Type Code	Rate	Description
Type 1	\$ 1,271.00	Flashing signals on single track
Type 2	\$ 1,978.00	Flashing signals and gates on a single track
Type 3	\$ 1,481.00	Flashing signals with cantilever arm on a single track
Type 4	\$ 2,389.00	Flashing signals with cantilever arm with gates on a single track
Type 5	\$ 2,257.00	Flashing signals and gates on multiple tracks
Type 6	\$ 2,398.00	Flashing signals with cantilever arms and gates on a multiple track
Type 7	\$ 1,269.00	Flashing signals on a multiple track
Type 8	\$ 1,375.00	Flashing signals with cantilever arms on multiple track

\*\*\* Note: Actual Cost Per Agreement.

DOT	Road Crossing	Type Code	Description of Traffic Control Devices	Road Authority Maintenance Fee per PA354 of 1993
543868A	36th Stree SE	Type 3	Flashing signals with cantilever arm on a single track	2017 \$ 1,481.00
543869G	Eastern Avenue	Type 3	Flashing signals with cantilever arm on a single track	\$ 1,481.00
543870B	32nd Street	Type 3	Flashing signals with cantilever arm on a single track	\$ 1,481.00
543871H	Madison Avenue	Type 3	Flashing signals with cantilever arm on a single track	\$ 1,481.00
543874D	Buchanan Street	Type 3	Flashing signals with cantilever arm on a single track	\$ 1,481.00
545751Y	54th Street	Type 4	Flashing signals with cantilever arm with gates on a single track	\$ 2,389.00
545752F	50th Street	Type 4	Flashing signals with cantilever arm with gates on a single track	\$ 2,389.00
545753M	44th Street	Type 4	Flashing signals with cantilever arm with gates on a single track	\$ 2,389.00
545754U	36th Street	Type 4	Flashing signals with cantilever arm with gates on a single track	\$ 2,389.00
545755B	32nd Street	Type 4	Flashing signals with cantilever arm with gates on a single track	\$ 2,389.00

Total Annual Amount - City of Wyoming

\$	19,350.00
----	-----------

RESOLUTION NO. \_\_\_\_\_

RESOLUTION TO CONCUR WITH REPAIR OF A  
VACTOR TRUCK, RENTAL OF A VACTOR TRUCK  
AND TO AUTHORIZE PAYMENT TO JACK DOHENY COMPANIES, INC.

WHEREAS:

1. As detailed in the attached Staff Report, Jack Doheny Companies, Inc. repaired a Vactor truck at a cost of \$11,892.30.
2. During the repairs, Jack Doheny Companies, Inc. provided a rental Vactor truck in the amount of \$12,500.00.
3. It is recommended the City Council authorize payment to Jack Doheny Companies, Inc. in the total amount of \$24,392.30.
4. The repair and rental will require approval of the attached budget amendment.

NOW, THEREFORE, BE IT RESOLVED:

1. The City Council does hereby concur with the repair of a Vactor Truck, rental and authorizes payment to Jack Doheny Companies, Inc. in the total amount of \$24,392.30.
2. The City Council does hereby waive the provisions of Sections 2-252, 2-253, 2-254 and 2-256 of the City Code regarding publication and posting of bid notices, notification of bidders and the bid opening procedure.
3. The City Council does hereby approve the attached budget amendment.

Moved by Councilmember:

Seconded by Councilmember:

Motion Carried        Yes  
                                  No

I hereby certify that the foregoing Resolution was adopted by the City Council for the City of Wyoming, Michigan at a regular session held on February 5, 2018.

ATTACHMENTS:  
Budget Amendment  
Staff Report  
Invoices (2)

\_\_\_\_\_  
Kelli A. VandenBerg, Wyoming City Clerk

Resolution No. \_\_\_\_\_

**CITY OF WYOMING BUDGET AMENDMENT**

**Date: February 5, 2018**

**Budget Amendment No. 047**

To the Wyoming City Council:

A budget amendment is requested for the following reason: To appropriate \$24,000.00 of budgetary authority for additional funding for the emergency repair and rental of the vactor truck as per the attached resolution.

<u>Description/Account Code</u>	<u>Current</u>	<u>Increase</u>	<u>Decrease</u>	<u>Amended</u>
<b><u>Sewer Fund</u></b>				
Public Works - Transmission - Rentals				
590-441-54200-940.000	500.00	4,000.00		4,500.00
Public Works - Transmission - Motor Pool Equipment Maintenance				
590-441-54200-947.200	30,000.00	4,000.00		34,000.00
Fund Balance/Working Capital (Fund 590)		-	8,000.00	
<b><u>Water Fund</u></b>				
Public Works - T and D - Rentals				
591-441-56200-940.000	500.00	4,000.00		4,500.00
Public Works - T and D - Motor Pool Equipment Maintenance				
591-441-56200-947.200	45,000.00	4,000.00		49,000.00
Public Works - T and D-Services - Rentals				
591-441-56700-940.000	500.00	4,000.00		4,500.00
Public Works - T and D-Services - Motor Pool Equipment Maintenance				
591-441-56700-947.200	60,000.00	4,000.00		64,000.00
Fund Balance/Working Capital (Fund 591)		-	16,000.00	

Recommended: Kate Baileys  
Senior Accountant

[Signature]  
Assistant City Manager

Motion by Councilmember \_\_\_\_\_, seconded by Councilmember \_\_\_\_\_ that the General Appropriations Act for Fiscal Year 2017-2018 be amended by adoption of the foregoing budget amendment.

Motion carried: Yes \_\_\_\_\_, No \_\_\_\_\_

I hereby certify that at a \_\_\_\_\_ meeting of the Wyoming City Council duly held on \_\_\_\_\_ the foregoing budget amendment was approved.

\_\_\_\_\_  
City Clerk

## STAFF REPORT

DATE: January 15, 2018

SUBJECT: Concurrence with Repair to Public Service Vactor #626-001

FROM: Ted Seil, Fleet Services Supervisor

Date of Meeting: February 5, 2018

---

### RECOMMENDATION:

It is recommended that the City Council concur with payment to Jack Doheny Companies, Inc. for emergency repairs totaling \$11,892.30 to Public Service Vactor Truck #626-001, and for the rental payment totaling \$12,500.00 to Jack Doheny Companies, Inc. for the rental use of a Vactor while the City equipment was out of service. The total amount for both items is \$24,392.30.

### SUSTAINABILITY CRITERIA

#### Environmental Quality

The Public Works Department is actively involved in the protection of Michigan's natural resources and the public's health and welfare. The use of a Vactor minimizes environmental impacts and damage that could be caused by more invasive digging equipment.

#### Social Equity

The repair and rental of this vehicle ensures that the utility repair services occur in an expedited, efficient manner without regard to income level or socio-economic status.

#### Economic Strength

The repair of the Vactor was the most economic means to restore the vehicle to daily service. Rental of a similar vehicle was also the most economic means to provide coverage and use during water and sewer emergencies, especially given that it was over the holiday season.

### QUALITY SERVICE IMPACT:

Proper repair of a vehicle is necessary to ensure that City functions can be performed in an effective and efficient manner. This is the most used piece of equipment in the city for repairs of water mains and sewers, and by repairing this vehicle we can insure its continued use and support of City services.

## DISCUSSION

On December 4, 2017, the Vactor truck's main pump was damaged by ice forming in it. An attempt was made to repair the truck in the Fleet Services shop; however, due to the complexity of the repair the truck was brought to its original manufacturer, Jack Doheny Companies, in Northville, Michigan. Originally it was thought that the repairs would be less than \$7,500.00. Once the repairs were started additional damage was found and the pump assembly had to be replaced instead of repaired. Additionally and while the truck was in the shop, it was given a thorough inspection by the manufacturer and other minor repairs were conducted. Repairs were completed on January 11, 2018 at a cost of \$11,892.00.

Because of the importance of the Vactor to the City infrastructure repair and maintenance, it was necessary to rent a similar vehicle for the period of time the City unit was being repaired. The rental amount during this period of time was \$12,500.00.

## BUDGET IMPACT

Sufficient funds are available in the following rental and maintenance accounts pending a budget amendment: 590-441-54200-940.000 (sewer transmission, rental), 590-441-54200-947.200 (sewer transmission, maintenance), 591-441-56200-940.000 (water mains, rental), 591-441-56200-947.200 (water mains, maintenance), 591-441-56700-940.000 (water services, rental), 591-441-56700-947.200 (water services, maintenance).

Remittance Address:  
 Jack Doheny Companies, Inc.  
 L-3846  
 Columbus, OH 43260-3846



Phone (248) 349-0904  
 Fax (248) 349-2774  
 www.DohenyCompanies.com

Customer WYOM001	** * INVOICE * **	Document W85536	Pg 1
		1/02/18	9:38
Sold To CITY OF WYOMING 2660 BURLINGAME, S.W. WYOMING MI 49509 0905		Ship To CITY OF WYOMING 2660 BURLINGAME, S.W. WYOMING MI 49509 0905	
616-530-7213		616-530-7213	

FOB JDC NORTHVILLE MI FACILITY

Br	Trk	Make	Model	Serial	Equipment	Meter	Sls	Customer	P.O.
001		VA	2115824P	12-07V-13228	000006136	4,745	KV	WYOMING/TED	

Ord	Ship	B/O	Description	Each	Amount
				Closed	12/30/17
UNITS RODDER PUMP NEEDS REPLACE/FROZEN CONTACT TED 616 530 7273 PLEASE PERFORM THE FREE JDC INSPECTION/PER VEROS THERE WILL BE AN FI SEGMENT FOR THIS.					
2	2		AQ 1AA8FJ8 FEMALE SWIVEL 1/2JIC	02BNCH*	7.75      15.50
4	4		AQ FC310-08RL 1/2" HYDRAULIC HOSE	02BNCH*	5.25      21.00
1	1		HF 2501-8-8 1/2MJ X 1/2MP 90 ELB	C1T64 *	7.77      7.77
1	1		JS E4F4-S 1/2" MALE X FEMALE	C1T25 *	7.50      7.50
1	1		HS TARIFF: 7307.29 USA RC E8800OMP REEL, SPRING RETRACT	32A04 *	475.00      475.00
1	1		HS TARIFF: 8424.90.00.90 V3 20189DJD	C1T18 *	3.84      3.84

CONTINUED

SEE REVERSE SIDE FOR SALE TERMS AND CONDITIONS  
 PLEASE NOTE NEW REMITTANCE ADDRESS

Remittance Address:  
 Jack Doheny Companies, Inc.  
 L-3846  
 Columbus, OH 43260-3846



Phone (248) 349-0904  
 Fax (248) 349-2774  
 www.DohenyCompanies.com

Customer WYOM001	** * INVOICE * **	Document W85536	Pg 2
		1/02/18	9:38
Sold To		Ship To	
CITY OF WYOMING 2660 BURLINGAME, S.W. WYOMING MI 49509 0905		CITY OF WYOMING 2660 BURLINGAME, S.W. WYOMING MI 49509 0905	
616-530-7213		616-530-7213	

FOB JDC NORTHVILLE MI FACILITY

Br	Trk	Make	Model	Serial	Equipment	Meter	Sls	Customer	P.O.
001		VA	2115824P	12-07V-13228	000006136	4,745	KV	WYOMING/TED	

Ord	Ship	B/O	Description	Each	Amount
1	1		MALE COUPLER 1/2 V3 31014AVJD 1/2" X 50' LEAD *ALSO SEE V1 31014AVJD*	61B02 *	130.00
			HS TARIFF: 4009.42		
1	1		V3 40029KJD REBUILD KIT 40029 AB-6815-700-KIT	C1T18 *	16.70
1	1		V3 40575JD VALVE, BALL, 1/2, 5800 HS TARIFF: 7326.90 USA TRI-XHP2W-CS-005	62END *	57.75
1	1		V3 46846HRJD 5000PSI WATER GAUG A *GAUGE ASSEMBLY FOR THE HOSE REEL*	C1T19 *	60.00
1	1		VA 20188A FEMALE COUPLER 1/2	C1T18 *	39.15
2	2		VA 507171 2" DISCHARGE VALVE	C1T27 *	245.89
2	2		VA 507349 CHECK VALVE, 3	C1T27 *	368.84
1	1		VA 62180XR	30END *	7,500.00

CONTINUED

SEE REVERSE SIDE FOR SALE TERMS AND CONDITIONS  
 PLEASE NOTE NEW REMITTANCE ADDRESS

Remittance Address:  
 Jack Doheny Companies, Inc.  
 L-3846  
 Columbus, OH 43260-3846



Phone (248) 349-0904  
 Fax (248) 349-2774  
 www.DohenyCompanies.com

Customer WYOM001	** * INVOICE * **	Document W85536	Pg 3
		1/02/18	9:38
Sold To CITY OF WYOMING 2660 BURLINGAME, S.W. WYOMING MI 49509 0905		Ship To CITY OF WYOMING 2660 BURLINGAME, S.W. WYOMING MI 49509 0905	
616-530-7213		616-530-7213	

FOB JDC NORTHVILLE MI FACILITY

Br	Trk	Make	Model	Serial	Equipment	Meter	Sls	Customer	P.O.
001		VA	2115824P	12-07V-13228	000006136	4,745	KV	WYOMING/TED	

Ord	Ship	B/O	Description	Each	Amount
9	9		RODDER PUMP,OIL UP ZZ AW68	OIL *	9.25 83.25
			HYDRAULIC OIL CHARGE/GAL		
			TOTAL PARTS		9,646.92
17.75			LABOR		115.00 2,041.25
			SHOP SUPPLIES		204.13
			MICHIGAN MUNICIPAL TAX EXEMPT		N/C

\* Interested in receiving your invoices by email \*  
 \* For details call 800-336-4369 and ask for A/R \*

Total 11,892.30

SEE REVERSE SIDE FOR SALE TERMS AND CONDITIONS

PLEASE NOTE NEW REMITTANCE ADDRESS

Authorized Signature \_\_\_\_\_ Date \_\_\_\_\_ Pulled By \_\_\_\_\_ Checked By \_\_\_\_\_

Remittance Address:  
 Jack Doheny Companies, Inc.  
 L-3846  
 Columbus, OH 43260-3846



Phone (248) 349-0904  
 Fax (248) 349-2774  
 www.DohenyCompanies.com

Customer WYOM001 Document R30120	I N V O I C E	Invoice H06396  1/11/18	Pg 1  Reprint
Sold To CITY OF WYOMING 2660 BURLINGAME, S.W. WYOMING MI 49509 0905		Ship To TED CITY OF WYOMING 2660 BURLINGAME, S.W. WYOMING MI 49509 0905	
616-530-7213		616-530-7213	

FOB JDC NORTHVILLE MI FACILITY

Br	Trk	Make	Model	Serial	Equipment	Meter	Sls	Customer	P.O.
001							KV	24344	6-30-08

Ord	Ship	Description	Each	Amount
		Taken By MATT FORD	Ordered	12/22/17
		Rental Contract R30120		
		Period: 12/22/17 Thru 1/11/18		
1	1	VA 000014563 21151024P100A 17-04V-16724 RB49653/VACTOR 21151024 100G P Hours: 61.00 RENTAL OF A VACTOR COMBINATION SEWER CLEANER MOUNTED ON A 2018 KENWORTH CHASSIS S/N 17-04V-16724 VIN 1NKZL40XXJJ181850 GROUP: COMB - COMBINATION SEWER CLEANER MODEL: 21151024P100A RENTAL START DATE:12/22/17 RENTAL END DATE:01/11/17 MICHIGAN MUNICIPAL TAX EXEMPT	12,500.00	12,500.00
				N/C

\* Interested in receiving your invoices by email \*  
 \* For details call 800-336-4369 and ask for A/R \*

Total	12,500.00
-------	-----------

SEE REVERSE SIDE FOR SALE TERMS AND CONDITIONS  
 PLEASE NOTE NEW REMITTANCE ADDRESS

RESOLUTION NO. \_\_\_\_\_

RESOLUTION TO EXTEND THE BID FROM CORE AND MAIN, METRON-FARNIER  
AND FERGUSON WATERWORKS AND ACCEPT A QUOTATION FROM ETNA SUPPLY  
FOR WATER METERS, STRAINERS AND METER EQUIPMENT

WHEREAS:

1. As detailed in the attached Staff Report, water meters, strainers and metering equipment are purchased as needed as an on-going replacement programing.
2. Core and Main, Metron-Farnier and Ferguson Waterworks have offered to extend their current bid pricing through February 6, 2019.
3. ETNA Supply submitted a quotation to extend their current bid pricing with a 3% increase through February 6, 2019.
4. It is estimated the City will spend approximately \$140,000 over the next year.
5. Funds to purchase the water meters, strainers and meter equipment are available in the water fund, transmission and distribution meters account number 591-441-565-775000.

NOW, THEREFORE, BE IT RESOLVED:

1. The City Council does hereby authorize extending Core and Main, Metron-Farnier and Ferguson Waterworks bid pricing for water meters, strainers and metering equipment.
2. The City Council does hereby accept a quote from ETNA Supply to extend their current bid pricing with a 3% increase.
3. The City Council does hereby waive the provisions of Sections 2-252, 2-253, 2-254 and 2-256 of the City Code regarding publication and posting of bid notices, notification of bidders and the bid opening procedure.

Moved by Councilmember:

Seconded by Councilmember:

Motion Carried        Yes  
                                  No

I hereby certify that the foregoing Resolution was adopted by the City Council for the City of Wyoming, Michigan at a regular session held on February 5, 2018.

ATTACHMENTS:  
Staff Report  
Tabulation Sheets

\_\_\_\_\_  
Kelli A. VandenBerg, Wyoming City Clerk

Resolution No. \_\_\_\_\_

## STAFF REPORT

DATE: January 23, 2018

SUBJECT: Bid Extension and Quotation Acceptance – Water Meters, Strainers, and Meter Equipment

FROM: Aaron Vis, Assistant Director of Public Works

Date of Meeting: February 5, 2018

---

### RECOMMENDATION:

It is recommend that the City Council extend the bid for water meters, strainers, and meter equipment to the low bidders Core and Main (formerly HD Supply), Metron-Farnier and Ferguson Waterworks (formerly Michigan Meter) in the amounts shown on the attached bid tabulation sheet. It is also recommended that the City Council accept the quotation for water meters, strainers, and meter equipment from ETNA Supply in the amounts shown on the attached bid tabulation sheet.

### SUSTAINABILITY CRITERIA:

Environmental Quality – All water meters and strainers meet the latest American Water Works Association (AWWA), National Sanitation Foundation (NSF) and American National Standards Institute (ANSI) standards. Water meters and strainers meet the definition of “lead free” as defined within the Safe Drinking Water Act.

Social Equity –Water meters are replaced depending on meter age and condition without regard to income level or socioeconomic status.

Economic Strength – The diversity of water meters bid allows City staff to match the best meter with the most appropriate application, ensuring fair and equitable water and sewer usage and billing.

### QUALITY SERVICE IMPACT:

Water meters are used for billing both water and sewer use for all customers in the City. The diversity of meters awarded will ensure that each customer has a properly sized, accurate, and environmentally sound meter.

### DISCUSSION:

On December 6, 2016 four bids were received for water meters, strainers and meter equipment out of twenty six invitations to bid that were sent to prospective bidders. On February 6, 2017, the bid was awarded to the four bidders per resolution number 25681 for a period of one year. Bid extension pricing was recently received and is shown on the attached tabulation sheets. Core

and Main, Metron-Farnier, and Ferguson Waterworks maintained their 2017 pricing, while ETNA Supply increased their prices by 3%. These companies are Michigan's sole suppliers of the meters listed, per the requirements of the meter manufacturers. The unit prices received are good for a period of one year. It is estimated that the City will spend approximately \$140,000 on water meters, strainers and metering equipment over the next year.

There are roughly 23,000 water meters within the City. Approximately 3,000 of these meters are industrial or commercial in nature; the remaining for residential purposes. About half of the water meters in the City are in excess of ten years old. The City has an on-going replacement program, replacing or newly installing approximately 750 meters a year.

Traditional water meter reading occurs by a person walking house-to-house, touching a reading device to a touchpad located outside of the house, and synchronizing with the reading software upon return to the office location. Many utilities today are metered through "smart meters", or meters that have the capacity to record real-time (or near real-time) utility consumption and transmit the information at regular intervals back to the utility and consumer. Over the past several years, staff have piloted and evaluated several different smart meter technologies in our service area. Currently, staff is investigating the potential application and financial viability of implementing smart water meter technology within the City and on a regional basis.

The water meters provided by all bidders can be either read through the traditional reading method or by using smart meter technology.

**BUDGET IMPACT:**

Sufficient funds are available in the water fund, transmission and distribution, meters account number 591-441-56500-775.000.

City of Wyoming, Michigan  
EXTENSION OF BIDS FOR  
WATER METERS, STRAINERS, AND METER EQUIPMENT

**RESIDENTIAL WATER METERS**

Positive Displacement Type

		CORE & MAIN			ETNA SUPPLY			FERGUSON WATERWORKS			METRON-FARNIER		
Description	Specification	Inside	Pit	Rebuild Kit	Inside	Pit	Rebuild Kit	Inside	Pit	Rebuild Kit	Inside	Pit	Rebuild Kit
		Application Bid Price (each)	Application Bid Price (each)		Application Bid Price (each)	Application Bid Price (each)		Application Bid Price (each)	Application Bid Price (each)		Application Bid Price (each)	Application Bid Price (each)	
5/8" X 3/4" Positive displacement type with	Neptune T-10 Encoder							\$101.00	\$115.00	\$33.00			
1" Positive displacement type with register	Neptune T-10 Encoder							\$202.00	\$216.00	\$53.00			
5/8" X 3/4" Positive displacement type with	Sensus SR11				\$88.84	\$103.00							
1" Positive displacement type with register	Sensus SR11				\$167.89	\$185.40							
5/8" X 3/4" Positive displacement type with	Sensus AccuStream				\$79.31	\$87.55							
1" Positive Displacement type with register	Sensus AccuStream				\$139.05	\$149.35							
Electromagnetic Type													
3/4" X 3/4" Electromagnetic type with register	Sensus iPEarl				\$133.90	\$133.90							
1" Electromagnetic type with register	Sensus iPEarl				\$206.00	\$206.00							
Ultrasonic Type													
5/8" X 3/4" Ultrasonic type with register	Neptune Mach 10							\$187.00	\$187.00	N/A			
1" Ultrasonic type with register	Neptune Mach 10							\$254.00	\$254.00	N/A			

**COMMERCIAL WATER METERS**

Turbine Meter with Strainer

		CORE & MAIN			ETNA SUPPLY			FERGUSON WATERWORKS			METRON-FARNIER		
Description	Specification	Inside Application	Pit Application	Rebuild Kit	Inside Application	Pit Application	Rebuild Kit	Inside Application	Pit Application	Rebuild Kit	Inside Application	Pit Application	Rebuild Kit
		Bid Price (each)	Bid Price (each)		Bid Price (each)	Bid Price (each)		Bid Price (each)	Bid Price (each)		Bid Price (each)	Bid Price (each)	
1.5" Turbine type with strainer and register	Neptune High Performance Turbine							\$976.00	\$976.00	\$325.00			
2" Turbine type with strainer and register	Neptune High Performance Turbine							\$976.00	\$976.00	\$325.00			
3" Turbine type with strainer and register	Neptune High Performance Turbine							\$1,700.00	\$1,700.00	\$475.00			
4" Turbine type with strainer and register	Neptune High Performance Turbine							\$2,541.00	\$2,541.00	\$625.00			
6" Turbine type with strainer and register	Neptune High Performance Turbine							\$4,300.00	\$4,300.00	\$925.00			
8" Turbine type with strainer and register	Neptune High Performance Turbine							\$6,698.00	\$6,698.00	\$1,225.00			
10" Turbine type with strainer and register	Neptune High Performance Turbine							\$10,653.00	\$10,653.00	\$1,525.00			
1.5" Turbine type with strainer and register	Sensus Omni				\$772.50	\$772.50	\$654.05						
2" Turbine type with strainer and register	Sensus Omni				\$906.40	\$906.40	\$654.05						
3" Turbine type with strainer and register	Sensus Omni				\$1,133.00	\$1,133.00	\$736.45						
4" Turbine type with strainer and register	Sensus Omni				\$2,199.05	\$2,199.05	\$736.45						
6" Turbine type with strainer and register	Sensus Omni				\$3,563.80	\$3,563.80	\$1,354.45						
8" Turbine type with strainer and register	Sensus Omni				\$8,497.50	\$8,497.50	\$1,802.50						
10" Turbine type with strainer and register	Sensus Omni				\$12,154.00	\$12,154.00	\$1,802.50						

**COMMERCIAL WATER METERS**

Turbine Meter Without Strainer

		CORE & MAIN			ETNA SUPPLY			FERGUSON WATERWORKS			METRON-FARNIER		
Description	Specification	Inside	Pit	Rebuild Kit	Inside	Pit	Rebuild Kit	Inside	Pit	Rebuild Kit	Inside	Pit	Rebuild Kit
		Application Bid Price (each)	Application Bid Price (each)		Application Bid Price (each)	Application Bid Price (each)		Application Bid Price (each)	Application Bid Price (each)		Application Bid Price (each)	Application Bid Price (each)	
1.5" Turbine type with register	Neptune High Performance Turbine							\$574.00	\$574.00	\$325.00			
2" Turbine type with register	Neptune High Performance Turbine							\$574.00	\$574.00	\$325.00			
3" Turbine type with register	Neptune High Performance Turbine							\$989.00	\$989.00	\$475.00			
4" Turbine type with register	Neptune High Performance Turbine							\$1,291.00	\$1,291.00	\$625.00			
6" Turbine type with register	Neptune High Performance Turbine							\$2,438.00	\$2,438.00	\$925.00			
8" Turbine type with register	Neptune High Performance Turbine							\$3,573.00	\$3,573.00	\$1,225.00			
10" Turbine type with register	Neptune High Performance Turbine							\$5,612.00	\$5,612.00	\$1,525.00			
1.5" Turbine type with register	Sensus Omni												
2" Turbine type with register	Sensus Omni				\$906.40	\$906.40							
3" Turbine type with register	Sensus Omni												
4" Turbine type with register	Sensus Omni												
6" Turbine type with register	Sensus Omni												
8" Turbine type with register	Sensus Omni												
10" Turbine type with register	Sensus Omni												

**COMMERCIAL WATER METERS**

Compound Meter

		CORE & MAIN		ETNA SUPPLY		FERGUSON WATERWORKS		METRON-FARNIER	
Description	Specification	Bid Price (each)	Rebuild Kit (each)	Bid Price (each)	Rebuild Kit (each)	Bid Price (each)	Rebuild Kit (each)	Bid Price (each)	Rebuild Kit (each)
2" Compound type with register	Neptune Tru/Flo					\$1,434.00	\$655.00		
3" Compound type with register	Neptune Tru/Flo					\$2,008.00	\$954.00		
4" Compound type with register	Neptune Tru/Flo					\$2,724.00	\$1,250.00		
6" Compound type with register	Neptune Tru/Flo					\$4,588.00	\$1,850.00		
8" Compound type with register	Neptune Tru/Flo					\$14,000.00 HP Protectuss III	N/A		
10" Compound type with register	Neptune Tru/Flo					\$16,236.00 HP Protectuss III	N/A		
2" Compound type with register	Sensus Omni C2			\$1,426.55	\$1,086.65				
3" Compound type with register	Sensus Omni C2			\$1,807.65	\$1,086.65				
4" Compound type with register	Sensus Omni C2			\$3,141.50	\$1,735.55				
6" Compound type with register	Sensus Omni C2			\$5,422.95	\$2,523.50				
8" Compound type with register	Sensus Omni C2			\$8,497.50	\$2,703.75				
10" Compound type with register	Sensus Omni C2			\$11,845.00	\$2,703.75				

**COMMERCIAL WATER METERS**

Single Jet Meter

		CORE & MAIN			ETNA SUPPLY			FERGUSON WATERWORKS			METRON-FARNIER		
Description	Specification	Inside Application	Pit Application	Rebuild Kit	Inside Application	Pit Application	Rebuild Kit	Inside Application	Pit Application	Rebuild Kit	Inside Application	Pit Application	Rebuild Kit
		Bid Price (each)	Bid Price (each)		Bid Price (each)	Bid Price (each)		Bid Price (each)	Bid Price (each)		Bid Price (each)	Bid Price (each)	
1.5" Single jet type with Innov8 electronic register	Metron-Farnier Spectrum Series										\$585.00	\$585.00	\$300.00
2" Single jet type with Innov8 electronic register	Metron-Farnier Spectrum Series										\$895.00	\$895.00	\$400.00
3" Single jet type with Innov8 electronic register	Metron-Farnier Spectrum Series										\$1,450.00	\$1,450.00	\$550.00
4" Single jet type with Innov8 electronic register	Metron-Farnier Spectrum Series										\$2,450.00	\$2,450.00	\$730.00
6" Single jet type with Innov8 electronic register	Metron-Farnier Spectrum Series										\$3,450.00	\$3,450.00	\$950.00
8" Single jet type with Innov8 electronic register	Metron-Farnier Spectrum Series										\$5,450.00	\$5,450.00	\$1,350.00
1.5" Single jet type with Innov8-VN electronic register	Metron-Farnier Spectrum Series										\$785.00	\$785.00	\$300.00
2" Single jet type with Innov8-VN electronic register	Metron-Farnier Spectrum Series										\$1,095.00	\$1,095.00	\$400.00
3" Single jet type with Innov8-VN electronic register	Metron-Farnier Spectrum Series										\$1,650.00	\$1,650.00	\$550.00
4" Single jet type with Innov8-VN electronic register	Metron-Farnier Spectrum Series										\$2,650.00	\$2,650.00	\$730.00
6" Single jet type with Innov8-VN electronic register	Metron-Farnier Spectrum Series										\$3,650.00	\$3,650.00	\$950.00
8" Single jet type with Innov8-VN electronic register	Metron-Farnier Enduro Series										\$5,650.00	\$5,650.00	\$1,350.00

**COMMERCIAL WATER METERS**

Positive Displacement Meter

		CORE & MAIN			ETNA SUPPLY			FERGUSON WATERWORKS			METRON-FARNIER		
Description	Specification	Inside Application	Pit Application	Rebuild Kit	Inside Application	Pit Application	Rebuild Kit	Inside Application	Pit Application	Rebuild Kit	Inside Application	Pit Application	Rebuild Kit
		Bid Price (each)	Bid Price (each)		Bid Price (each)	Bid Price (each)		Bid Price (each)	Bid Price (each)		Bid Price (each)	Bid Price (each)	
1.5" Positive displacement type with register	Neptune T-10 E-coder							\$397.00	\$411.00	\$112.00			
2" Positive displacement type with register	Neptune T-10 E-coder							\$517.00	\$531.00	\$145.00			

**FIRE HYDRANT WATER METERS**

		CORE & MAIN	ETNA SUPPLY	FERGUSON WATERWORKS	METRON-FARNIER
Description	Specification	Bid Price (each)	Bid Price (each)	Bid Price (each)	Bid Price (each)
3" Fire hydrant type with register	Metron-Farnier Voyager 80 with Innov8 Electronic Register				\$1,250.00
3" Fire hydrant type with register	Neptune Fire Hydrant Meter			\$980.00	
3" Fire hydrant type with register	Sensus Omni Fire Hydrant (H2) Meter		\$1,550.00		

**STRAINERS**

		CORE & MAIN	ETNA SUPPLY	FERGUSON WATERWORKS	METRON-FARNIER
Description	Specification	Bid Price (each)	Bid Price (each)	Bid Price (each)	Bid Price (each)
1.5"	CORE & MAIN: Mars NL Bronze Strainer	\$215.29			
	FERGUSON: Bronze Strainer			\$402.00	
2"	CORE & MAIN: Mars NL Bronze Strainer	\$256.62			
	FERGUSON: Bronze Strainer			\$402.00	
3"	CORE & MAIN: Mars NL Bronze Strainer	\$456.03			
	FERGUSON: Bronze Strainer			\$711.00	
	METRON: NSF Approved Z-Plate Strainer				\$425.00
4"	CORE & MAIN: Mars NL Bronze Strainer	\$687.50			
	FERGUSON: Bronze Strainer			\$1,250.00	
	METRON: NSF Approved Z-Plate Strainer				\$750.00
6"	CORE & MAIN: Mars NL Bronze Strainer	\$1,163.70			
	FERGUSON: Bronze Strainer			\$1,862.00	
	METRON: NSF Approved Z-Plate Strainer				\$975.00
8"	CORE & MAIN: Mars Z-Plate Strainer (steel powder coated)	\$772.74			
	FERGUSON: Bronze Strainer			\$3,125.00	
10"	CORE & MAIN: Mars Z-Plate Strainer (steel powder coated)	\$1,075.20			
	FERGUSON: Bronze Strainer			\$5,041.00	

**INNOV8-VN ELECTRONIC REGISTER**

		CORE & MAIN	ETNA SUPPLY	FERGUSON WATERWORKS	METRON-FARNIER
Description		Bid Price (each)	Bid Price (each)	Bid Price (each)	Bid Price (each)
Innov8-VN Electronic Register					\$110.00

**METER INTERFACE UNIT**

Description	CORE & MAIN		ETNA SUPPLY		FERGUSON WATERWORKS		METRON-FARNIER	
	Non-Pit Application Bid Price (each)	Pit Application Bid Price (each)	Non-Pit Application Bid Price (each)	Pit Application Bid Price (each)	Non-Pit Application Bid Price (each)	Pit Application Bid Price (each)	Non-Pit Application Bid Price (each)	Pit Application Bid Price (each)
	Neptune R-900					\$96.00	\$110.00	
Sensus 510M (non-pit) single port			\$140.00					
Sensus 510M (non-pit) dual port			\$150.00					
Sensus 520M (pit) single port			\$140.00					
Sensus 520M (pit) dual port			\$150.00					

**WALL MOUNT TOUCH PAD**

Description	CORE & MAIN	ETNA SUPPLY	FERGUSON WATERWORKS	METRON-FARNIER
	Bid Price (each)	Bid Price (each)	Bid Price (each)	Bid Price (each)
Wall mount touch pad		\$21.00	\$7.00	

**TOUCH PAD METER READING DEVICE**

Description	Specification	CORE & MAIN	ETNA SUPPLY	FERGUSON WATERWORKS	METRON-FARNIER
		Bid Price (each)	Bid Price (each)	Bid Price (each)	Bid Price (each)
Meter reading device	(no specs provided)		\$8,000.00		
	Advantage Probe			\$1,227.00	

RESOLUTION NO. \_\_\_\_\_

RESOLUTION TO ACCEPT A PROPOSAL FROM THYSSENKRUPP ELEVATOR  
TO PERFORM CORRECTIVE MAINTENANCE ON AN ELEVATOR

WHEREAS:

1. As detailed in the attached Staff Report, a proposal was received from ThyssenKrupp Elevator to perform corrective maintenance on an elevator at the Water Treatment Plant in the total estimated amount of \$8,892.00.
2. It is recommended the City Council accept the proposal.
3. Funds are available in the water treatment repairs and maintenance account number 591-591-55300-930000.

NOW, THEREFORE, BE IT RESOLVED:

1. The City Council does hereby accept a proposal from ThyseenKrupp Elevator to perform corrective maintenance on an elevator in the total estimated amount of \$8,892.00.

Moved by Councilmember:  
Seconded by Councilmember:  
Motion Carried        Yes  
                                  No

I hereby certify that the foregoing Resolution was adopted by the City Council for the City of Wyoming, Michigan at a regular session held on February 5, 2018.

\_\_\_\_\_  
Kelli A. VandenBerg, Wyoming City Clerk

ATTACHMENTS:  
Staff Report

Resolution No. \_\_\_\_\_

## STAFF REPORT

Date: January 29, 2018

Subject: Acceptance of Proposal to Perform Corrective Maintenance on One Elevator

From: Tom Wilson, Utility Maintenance Manager

Meeting Date: February 5, 2018

---

### **Recommendation:**

It is recommended that the City Council accept the proposal from ThyssenKrupp Elevator to perform corrective maintenance on one elevator located within the City of Wyoming Water Treatment Plant. The proposal includes the necessary manpower, tools, and test equipment to perform the corrective maintenance at a cost of \$8,892.00. Any additional parts deemed necessary for replacement or repair will be quoted separately.

### **Sustainability Criteria:**

Environmental Quality – The Wyoming Utilities Department is actively engaged in the protection of Michigan’s natural water environment and the public health of Wyoming’s citizens. As part of our efforts to continue making a positive impact on the environment, it is necessary that our infrastructure and the equipment that keeps it running are maintained in a safe, reliable, and optimal working condition.

Social Equity – The Utility function within the City of Wyoming provides the same high quality service to all areas of the City without regard to income level or socio-economic status. All of Wyoming’s residents enjoy equal access to the benefits of our state-of-the-art wastewater and drinking water treatment technologies.

Economic Strength – Regular and proper upkeep of City equipment contributes to the efficiency of the equipment, and to the prevention of untimely and costly repairs or replacement that could potentially interrupt the day-to-day operations of the Plant.

### **Quality Service Impact:**

Being proactive in replacing all worn out parts provides dependability and longevity of the elevator thereby assuring safety when the elevator is needed.

**Discussion:**

A proposal was received from ThyssenKrupp Elevator to perform corrective maintenance on one elevator located within the Water Treatment Plant. ThyssenKrupp Elevator will furnish and install an ADA compliant autodial phone, install and program a new operator board, and provide and install a selector tape which will improve leveling and performance. All of the parts and equipment mentioned previously have failed due to the atmospheric conditions of where the elevator is located. Per State law, this work must be performed by a licensed elevator repair company. ThyssenKrupp Elevator is a licensed company and is currently contracted to perform all of our quarterly inspections and service.

**Budget Impact:**

Based on the information presented, it is recommended that the City Council accept the proposal as submitted by ThyssenKrupp Elevator to perform corrective maintenance on one elevator at a cost of \$8,892.00. Adequate funds exist in the Water Treatment Repairs and Maintenance Account 591-591-55300-930000.

RESOLUTION NO. \_\_\_\_\_

RESOLUTION TO CONCUR WITH ADDITIONAL REPAIRS OF  
TWO PUMPS AT THE WATER TREATMENT PLANT

WHEREAS:

1. As detailed in the attached staff report, on November 20, 2017, City Council adopted Resolution #29543, authorizing the repair of two pumps at the Water Treatment Plant in the total amount of \$45,501.00.
2. HECO, Inc. submitted revised quotes to include additional repairs.
3. It is recommended the City Council authorize the additional repairs and authorize payment to HECO, Inc. in the total amount of \$56,453.00.
4. Funds for the repairs are available in the Water Treatment Plant Repairs and Maintenance account number 591-591-55300-930000.

NOW, THEREFORE, BE IT RESOLVED:

1. The City Council does hereby concur with the additional repairs of two pumps at the Water Treatment Plant.
2. The City Council does hereby authorize payment to HECO, Inc. in the total amount of \$56,453.00.

Moved by Councilmember:  
Seconded by Councilmember:  
Motion Carried Yes  
No

I hereby certify that the foregoing Resolution was adopted by the City Council for the City of Wyoming, Michigan at a regular session held on February 5, 2018.

ATTACHMENTS:  
Staff Report  
Quote (2)

\_\_\_\_\_  
Kelli A. VandenBerg, Wyoming City Clerk

## STAFF REPORT

Date: January 29, 2018

Subject: Award of Revised Quote for Service of Two Pump Motors

From: Tom Wilson, Utility Maintenance Manager

Meeting Date: February 5, 2018

---

### RECOMMENDATION:

It is recommended that the City Council award the revised quotes from HECO Industrial Service Groups to repair one 1500-horsepower High Service Pump Motor and one 200-horsepower Transfer Pump Motor at a cost of \$56,453.00 which includes delivery.

### SUSTAINABILITY CRITERIA:

Environmental Quality – The Utilities Department is actively engaged in the protection of Michigan’s natural water environment and the public health of Wyoming’s citizens. As part of our efforts to continue making a positive impact on the environment, it is necessary that our infrastructure and the equipment that keeps it running are maintained in a safe, reliable, and optimal working condition.

Social Equity – The Utility function within the City of Wyoming provides the same high quality service to all areas of the City without regard to income level or socio-economic status. All of Wyoming’s residents enjoy equal access to the benefits of our state-of-the-art wastewater and drinking water treatment technologies.

Economic Strength – Regular and proper upkeep of City equipment contributes to the efficiency of the equipment and to the prevention of untimely and costly repairs or replacement that could potentially interrupt the day-to-day operations of the Plant.

### QUALITY SERVICE IMPACT:

Working with a quality motor repair service assures that the motors that are repaired will function according to specifications, therefore providing water to our wholesale customers and City residents.

### DISCUSSION:

On November 20, 2017, per resolution 29543, City Council approved HECO Industrial Service Groups to repair one 1500-horsepower High Service Pump Motor and one 250-horsepower Transfer Pump Motor at a cost of \$45,501.00. Four motor repair firms were provided a scope of work to be performed on the aforementioned motors of which HECO’s quote was the low quote of the four.



Upon completing their inspection of both motors HECO has found that a thrust bearing and some additional but minor work needs to be performed on the 250 HP motor. However, on the 1500 HP motor quite a bit of machine work is required to bring the motor back to factory specifications. The revised total quotes to perform these additional repairs is \$56,453.00 or a net increase of \$10,952.00.

**BUDGET IMPACT:**

Based on the information presented, it is recommended that the City Council accept the revised quotes as received by HECO Industrial Service Groups, to repair the two motors in the total amount of \$56,453.00. Adequate funds exist in the Water Treatment Plant Repairs & Maintenance Account #591-591-55300-930000.

**Attachments**

HECO Quotes



**HECO, INC.**  
 3509 S. BURDICK STREET  
 KALAMAZOO, MI 49001  
 Phone: (269)-381-7200  
 Fax: (269)-381-0099

# Job Estimate

<b>Job No.:</b>	013639
<b>Recv'd Date:</b>	11/28/17
<b>Page:</b>	1

<b>Sold To:</b>	Customer Number: 007490	<b>Ship To:</b>	Ship To Number: 000001
	<b>CITY OF WYOMING</b> ACCOUNTING DEPT. P.O. BOX 905 WYOMING, MI 49509-0905		<b>WYOMING WTP</b> 16700 NEW HOLLAND STREET HOLLAND, MI 49424
<b>Contact:</b> TOM WILSON			

Job Number	Recv'd Date	Sales Code	Location	Ship Via	Terms
013639	11/28/17	30		OUR TRUCK	NET 30 DAYS

<b>Customer PO</b>	2018-00000344	<b>PO Release</b>		<b>Misc Number</b>	
--------------------	---------------	-------------------	--	--------------------	--

Description	Extension
Nameplate Data: HP:1500, SYNC. RPM:1200, VOLTAGE:4000, FRAME:6810PA, MFG:U.S. ELECTRIC, AMPS:190, SERIAL #:D7009884, TYPE:HV-5, INS. CLASS:B, SF:1.0, L.BRG.TYPE:6226, ACT. RPM:1185	
Special Instructions: 8' TALL, 10" OF SHAFT	
PICK UP REPAIR JOB DISMANTLE FOR COMPLETE RECONDITION REMOVE BEARINGS **OIL LEAK AT LOWER SIGHT GLASS** CLEAN AND RECONDITION ROTOR REWIND STATOR AND INSTALL NEW RTD'S CLEAN AND PAINT ALL MAJOR PARTS STEAM AND BAKE UPPER HOUSING CORE TEST BEFORE & AFTER BURN INSPECT UPPER KINGSBURY BEARING V.P.I. STATOR CLEAN/GRIND VPI OFF STATOR LABOR & MATERIALS TO DIP & BAKE ROTOR	

Repair estimate valid for 30 calendar days  
 from the above date.  
 Total is plus sales tax if applicable.  
 Based Upon Our Standard Terms And Conditions.

<b>Total</b>	Continued ...
--------------	---------------

**Received By:** \_\_\_\_\_ **Date:** \_\_\_\_\_

**Customer**



**HECO, INC.**  
 3509 S. BURDICK STREET  
 KALAMAZOO, MI 49001  
 Phone: (269)-381-7200  
 Fax: (269)-381-0099

# Job Estimate

<b>Job No.:</b>	013639
<b>Recv'd Date:</b>	11/28/17
<b>Page:</b>	2

<b>Sold To:</b>	Customer Number: 007490	<b>Ship To:</b>	Ship To Number: 000001
	<b>CITY OF WYOMING</b> ACCOUNTING DEPT. P.O. BOX 905 WYOMING, MI 49509-0905		<b>WYOMING WTP</b> 16700 NEW HOLLAND STREET HOLLAND, MI 49424
<b>Contact:</b> TOM WILSON			

Job Number	Recv'd Date	Sales Code	Location	Ship Via	Terms
013639	11/28/17	30		OUR TRUCK	NET 30 DAYS

<b>Customer PO</b>	2018-00000344	<b>PO Release</b>		<b>Misc Number</b>	
--------------------	---------------	-------------------	--	--------------------	--

Description	Extension
CLEAN/GRIND VARNISH OFF ROTOR	
CHROME CARRIER	
GRIND THRUST BRNG JOURNAL TO SIZE	
MANUFACTURE NEW COUPLING & KEY	
SLEEVE D.E. BEARING HOUSING	
SLEEVE D.E. INBOARD SEAL HOUSING	
CHECK ROTOR RUNOUT IN LATHE	
REPAIR D.E. EXTENSION	
WELD COUPLING IN UPPER HOUSING FOR SIGHT	
DRILL & TAP KINGSBURY FOR LIFTING	
REPAIR CARRIER KEYWAY AND MAKE NEW KEY	
DEGAUSS D.E./O.D.E. SHAFT EXTENSION	
DYNAMIC BALANCE ROTOR ASSEMBLY	
INSTALL NEW HEATERS	
INSTALL NEW BEARINGS	
REPLACE BEARING PROBES	
INSTALL NEW FELT IN ODE O.B. SEAL	
REMOVE O.D.E. STAND PIPE, SLEEVE O.D.E	
BEARING HOUSING THEN REINSTALL	
ASSEMBLE ALL PARTS	
FINAL ELECTRICAL TEST	
FINAL TEST RUN MOTOR AT FULL RATED VOLTS	

Repair estimate valid for 30 calendar days

<b>Total</b>	Continued ...
--------------	---------------

from the above date.

Total is plus sales tax if applicable.

Based Upon Our Standard Terms And Conditions.

**Received By:** \_\_\_\_\_ **Date:** \_\_\_\_\_

**Customer**





**HECO, INC.**  
 3509 S. BURDICK STREET  
 KALAMAZOO, MI 49001  
 Phone: (269)-381-7200  
 Fax: (269)-381-0099

# Job Estimate

<b>Job No.:</b>	013638
<b>Recv'd Date:</b>	11/28/17
<b>Page:</b>	1

<b>Sold To:</b>	Customer Number: 007490	<b>Ship To:</b>	Ship To Number: 000001
	<b>CITY OF WYOMING</b> ACCOUNTING DEPT. P.O. BOX 905 WYOMING, MI 49509-0905		<b>WYOMING WTP</b> 16700 NEW HOLLAND STREET HOLLAND, MI 49424
<b>Contact:</b> TOM WILSON			

Job Number	Recv'd Date	Sales Code	Location	Ship Via	Terms
013638	11/28/17	30		OUR TRUCK	NET 30 DAYS

<b>Customer PO</b>	2018-00000344	<b>PO Release</b>		<b>Misc Number</b>	
--------------------	---------------	-------------------	--	--------------------	--

Description	Extension
Nameplate Data: HP:250, SYNC. RPM:900, VOLTAGE:4000, FRAME:1589P, MFG:U.S. ELECTRIC, AMPS:35, SERIAL/ID#:J515490-54-01235-375, TYPE/CAT #:HU, UP. BRG. #:7228, L. BRG. #:6220, DESIGN:B, INS. CLASS:B, SF:1.15, ACT. RPM:880	
PICK UP MOTOR FROM WTP DISMANTLE FOR COMPLETE RECONDITION CLEAN AND RECONDITION ROTOR CLEAN AND RECONDITION STATOR CLEAN AND PAINT ALL MAJOR PARTS SLEEVE LEADS INCOMING CORE TEST LABOR & MATERIALS TO DIP & BAKE STATOR CLEAN/GRIND VARNISH OFF STATOR DYNAMIC BALANCE ROTOR WITH CARRIER INSTALL NEW BEARINGS INSTALL NEW SIGHT GLASSES ASSEMBLE ALL PARTS FINAL ELECTRICAL TEST	

Repair estimate valid for 30 calendar days  
 from the above date.

<b>Total</b>	Continued ...
--------------	---------------

Total is plus sales tax if applicable.  
 Based Upon Our Standard Terms And Conditions.

**Received By:** \_\_\_\_\_ **Date:** \_\_\_\_\_

**Customer**



RESOLUTION NO. \_\_\_\_\_

RESOLUTION FOR AWARD OF BIDS

WHEREAS:

1. Formal bids have been obtained on the below listed items.
2. The bids received have been reviewed and evaluated as per the attached Staff Report.

NOW, THEREFORE, BE IT RESOLVED:

1. The City Council does hereby award the bids for the listed items as recommended in the attached Staff Report and summarized below.

Item	Recommended Bidder	Cost
Generators	Weingartz	\$17,475.00
Trailer	Technology International, Inc.	\$9,611.70

Moved by Councilmember:  
Seconded by Councilmember:  
Motion Carried        Yes  
                                  No

I hereby certify that the foregoing Resolution was adopted by the City Council for the City of Wyoming, Michigan at a regular session held on February 5, 2018.

ATTACHMENT:  
Staff Report

\_\_\_\_\_  
Kelli A. VandenBerg, Wyoming City Clerk

Resolution No. \_\_\_\_\_

## STAFF REPORT

Date: January 24, 2018

Subject: Authorize the Purchase of Generators and Trailer

From: Russ Henckel, Assistant Director of Public Works

Meeting Date: February 5, 2018

---

### RECOMMENDATION:

It is recommended that the City Council authorize the purchase of five (5) commercial grade gas powered generators and an enclosed trailer for storage and transport in the total amount of \$27,086.70. The generators will be used to keep traffic signals operational during power outages.

### SUSTAINABILITY CRITERIA:

Environmental Quality – The City of Wyoming continually maintains and upgrades traffic signals in Wyoming and a few neighboring communities. By providing a safe and efficient traffic signal system during periods of power outages, Wyoming reduces pollutants from idling vehicles unnecessarily waiting at traffic signals.

Social Equity – Traffic signals and associated equipment are maintained throughout the City without regard to income level or socio-economic status.

Economic Strength – Providing an efficient traffic signal infrastructure adds to the economic strength of a community allowing safe and efficient pedestrian and vehicular travel during periods of interrupted power supply.

### QUALITY SERVICE IMPACT:

The trailer and power generators provide a quick response method to deliver generators during emergency power outages. The generators are of a capacity to allow for long, continuous supplemental power supply during power outages. Dependable traffic signals help ensure motorist and pedestrian safety in Wyoming.

### DISCUSSION:

On January 9, 2018, the City received three bids for five (5) generators. Twenty three invitations to bid were sent to prospective bidders. Also, on January 9, 2018 the City received one bid for a trailer. Fifty one invitations to bid were sent to prospective bidders.

The City of Wyoming has experienced widespread power outages during previous storm events or during other emergencies that cause the interruption of power. Wyoming traffic plans to upgrade traffic signal power generators to a “long run” type of generator. The new power generators would provide clean steady power to traffic signals during power outages and require

less frequent refueling to keep operational. Additionally, the generators would be kept in a new trailer for quick distribution to intersections during power emergencies. As shown below, Weingartz, low bid for the five long run power generators in the amount of \$17,475.00 and Technology International, Inc. provided the lone bid for the trailer unit in the amount of \$9,611.70.

		Each (Reduced to Net)	Est. Qty.	Total for Est. Quantity
Generators	Weingartz	\$3,495.00	5	\$17,475.00
	Hammersmith Equipment	\$3,535.00		\$17,675.00
	Preventative Maintenance Technologies	\$4,950.00		\$24,750.00
Trailer	Technology International, Inc.	\$9,611.70	1	\$9,611.70

It is recommended that the City Council authorize the purchase of the power generators and trailer.

**BUDGET IMPACT:**

Funds for the purchase of the generators and trailer are available in the Major Streets Traffic Account Tools and Supplies account number 202-441-47400-766000.

ORDINANCE NO. 1-18

AN ORDINANCE TO AMEND SECTION 90-32 OF THE CODE OF THE  
CITY OF WYOMING BY ADDING SUBSECTION (109) THERETO

THE CITY OF WYOMING ORDAINS:

Section 1. That Section 90-32 of the Code of the City of Wyoming is hereby amended by adding Subsection (109) thereto, to read as follows:

- (109) To rezone 2440, 2446, 2450 and 2520 Vangie Drive; 2453 Batt Drive; and 61, 71, 81, 101 and 111 Plaster Creek Boulevard from R-2 Single Family Residential to I-1 Light Industrial

Section 2. This ordinance shall be in full force and effect on the \_\_\_\_\_ day of \_\_\_\_\_, 2018.

I hereby certify that the above-entitled Ordinance was adopted by the City of Wyoming at a regular session of the City Council held on the \_\_\_\_\_ day of \_\_\_\_\_, 2018.

\_\_\_\_\_  
Kelli A. Vandenberg  
Wyoming City Clerk

Ordinance No. 1-18

January 24, 2018

Ms. Kelli A. Vandenberg  
City Clerk  
Wyoming, MI

**Subject:** Request to rezone 2440, 2446, 2450 and 2520 Vangie Drive; 2453 Batt Drive; and 61, 71, 81, 101 and 111 Plaster Creek Boulevard, SW from R-2 Single Family Residential to I-1 Light Industrial.

**Recommendation:** To approve the subject rezoning request.

Dear Ms. Vandenberg:

The above referenced request was reviewed by the Wyoming Planning Commission at its regular meeting on January 16, 2018. A motion was made by DeLange, supported by Goodheart, to recommend to City Council approval of the rezoning request. The motion passed unanimously. While a more detailed review is available in the Planning Commission minutes, the following is provided as basic background information.

Monsma Marketing has undertaken several expansions in the recent years, and continue to find a need for further growth. They have optioned ten properties to the east of their facility with the desire to rezone these properties to accommodate their growth. These properties are zoned R-2 Single Family Residential, and are undeveloped with the exception of a single residence.

The single family subdivisions to the north and east, which include the subject properties, were platted and developed prior to World War II. The subject area is encumbered by both the Plaster Creek floodplain and a significant hillside. As such, the streets were never constructed, and with the exception of one home, no development occurred.

Monsma Marketing, and their civil engineer consultant, has worked closely with the City and the MDEQ to facilitate their prior expansions. They believe they can obtain approval to, at a minimum, expand their tractor trailer storage yard into the rezoning area (see attached exhibits). Long term, they hope to be able to construct a warehouse building on this site, which is more problematic given the floodplain



CITY COUNCIL

Bill VerHulst   Dan Burrill   Kent Vanderwood   Marissa Postler   Robert Postema   Sam Bolt  
**Jack A. Poll, Mayor**

implications. If the requested rezoning is approved, staff would work closely with the applicant and the MDEQ to mitigate the floodplain impacts, construct a necessary retaining wall in the hillside, and retain as much existing tree cover and buffer yard as possible where adjoining the nearby residents. Depending on the development of that plan, additional buffering may also be requested by the City of the applicant.

Expansion of Monsma Marketing into this area also requires vacation of the undeveloped public street Vangie Drive, and possibly the undeveloped portions of Southview Street and Batt Drive. Vacation of any of these streets will require a process by the applicant and City. That process will follow if the requested rezoning is approved.

The City of Wyoming Land Use Plan was adopted in 2006. The Plan recommends that this area be used for low - medium density residential purposes, which conforms to the existing R-2 Single Family Residential zoning and nearby development. This pocket of residential is bounded by industrial designation along Buchanan Avenue to the west, and commercial designation along Division Avenue to the east. The development of the Land Use Plan did not evaluate the potential for this two acre site to be removed from the adjoining subdivisions.

The Development Review Team suggested the Planning Commission recommend to the City Council approval of the rezoning request. No public comments were provided.

Respectfully submitted,



---

Timothy Cochran, City Planner  
Planning and Development Department

cc: Curtis Holt, City Manager  
Rebecca Rynbrandt, Director of Community Services



Buchanan Ave.

Plaster Creek Blvd.

Proposed Rezoning

DETROIT ST

BLACKBURN ST

ANSONIA AVE

SOUTHVIEW ST

VANGIE DR

BATTERS

PLASTER CREEK BLVD

KEN-O-SHA DR

BAIT DR

CLAIRE ST

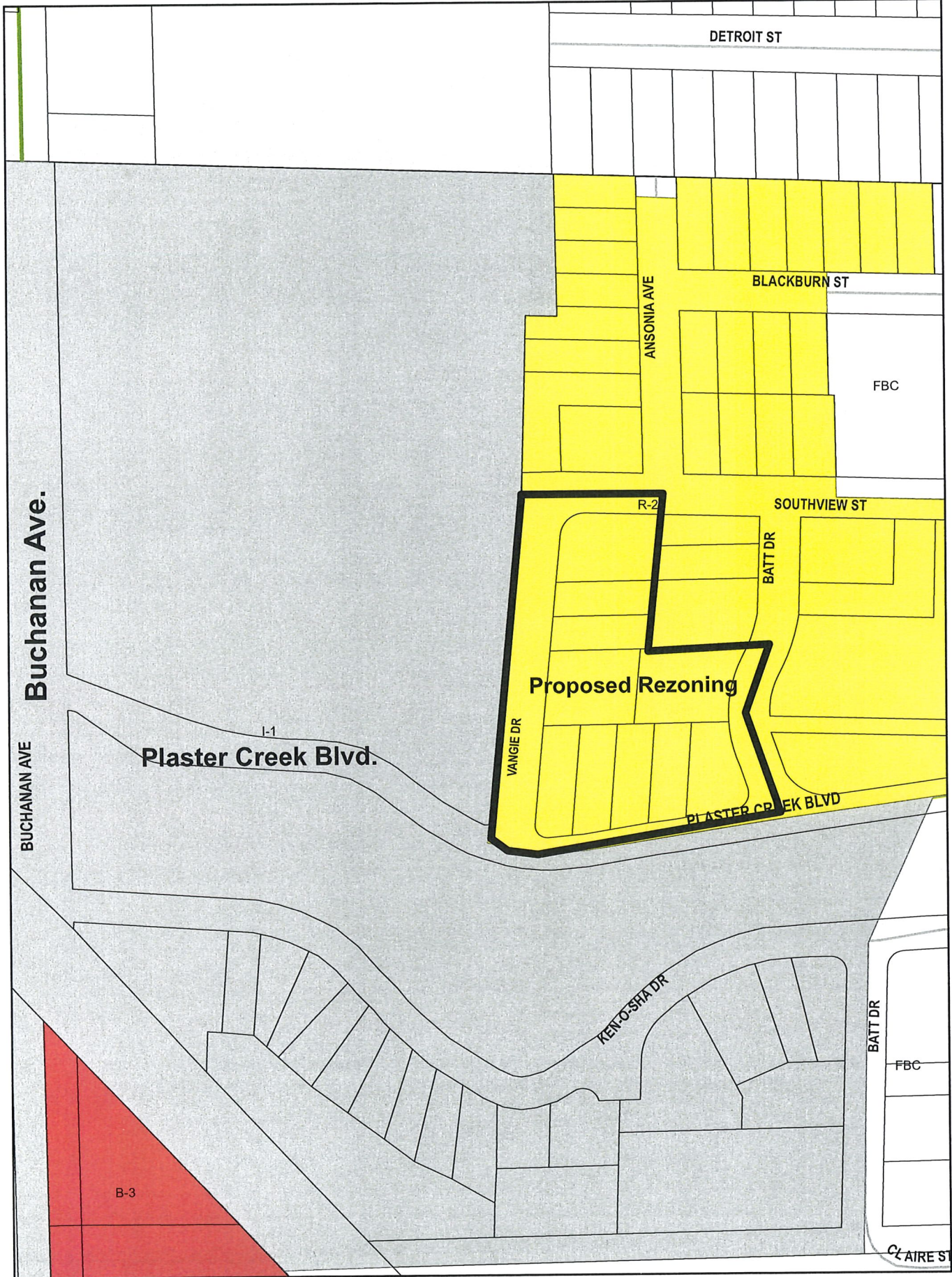

DETROIT ST

Buchanan Ave.

BUCHANAN AVE

Plaster Creek Blvd.

I-1

BLACKBURN ST

FBC

ANSONIA AVE

SOUTHVIEW ST

R-2

Proposed Rezoning

BATT DR

VANGIE DR

PLASTER CREEK BLVD

KEN-O-SHA DR

BATT DR

FBC

B-3

CLAIRE ST

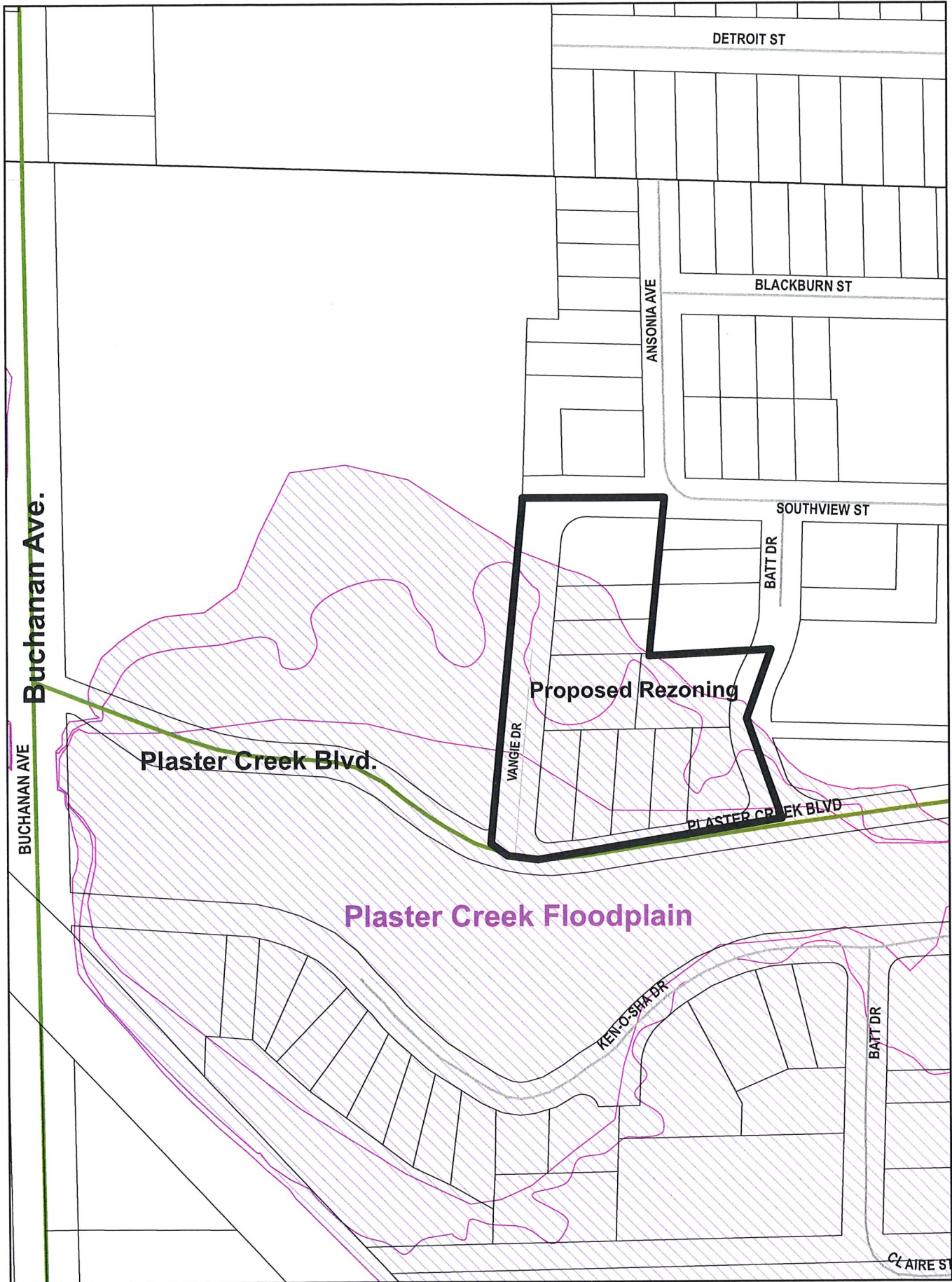

**Buchanan Ave.**

BUCHANAN AVE

**Plaster Creek Blvd.**

DETROIT ST

BLACKBURN ST

SOUTHVIEW ST

ANSONIA AVE

VANGIE DR

BATT DR

PLASTER CREEK BLVD

KENO-SHA DR

BATT DR

CLAIRE ST

**Proposed Rezoning**

**Plaster Creek Floodplain**



ARCHITECTS - ENGINEERS

**paradigm design**

300 S. MILLIKEN DRIVE  
GRAND RAPIDS, MI 49508  
616.785.5454

332 E. STATE STREET  
TRAVERSE CITY, MI 49684  
231.246.3030

PA@PARADIGMDESIGN.COM

PROJECT

**MONSMA  
ADDITIONAL  
PROPERTY**

CLIENT

**MONSMA MARKETING  
CORPORATION**

2450 BUCHANAN AVE SW  
GRAND RAPIDS, MI 49507

RELEASE DATE

DATE: 12-12-17  
DESCRIPTION: RECORDING REQUEST

PROJECT

1711143

SHEET

PHASE 2 SITE PLAN

C-103

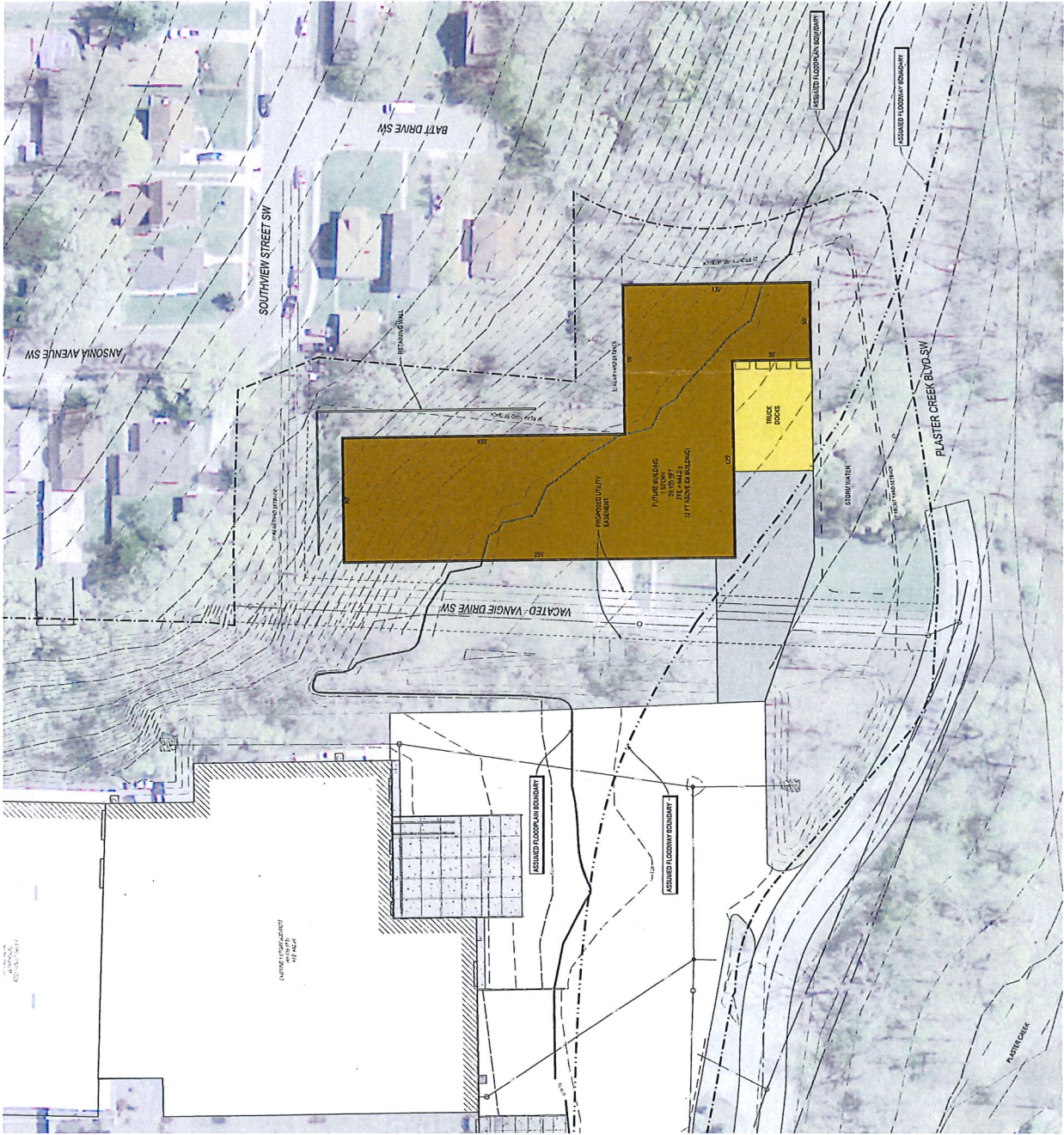
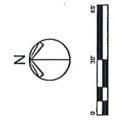

THIS PLAN IS THE PROPERTY OF PARADIGM DESIGN AND IS NOT TO BE REPRODUCED OR COPIED IN ANY MANNER WITHOUT THE WRITTEN PERMISSION OF PARADIGM DESIGN.